

Application examples

These examples only indicate some applications of the poppet valve but not include all functions

symbol C 	2/2-way circuit with two poppet valves and check valve at port A The check valve must be installed on the pipeline. Initial position: The flow is blocked and the maximum pressure is allowed. Due to the check valve at port A, the pressure is held in the actuator even when the pump is turned off. Switching position: The fluid flows freely and the maximum pressure is allowed. The oil is drained via port T. The only oil leakage occurring is that the oil flows to T during the switching process.	symbol U 	3/2-way circuit with a single poppet valve Initial position: Lifting The maintenance of position only depends on the stroke limit and the pressure at port P. Switching position: Descending
symbol U 	2/2-way circuit with a single poppet valve and check valve at port A The check valve must be installed on the pipeline. Initial position: The fluid flows freely and the maximum pressure is allowed. Due to the check valve at port A, the pressure is held in the actuator even when the pump is turned off. Switching position: The flow is blocked and the maximum pressure is allowed. The oil is drained via port T. The only oil leakage occurring is that the oil flows to port T during the switching process.	symbol C 	3/2-way circuit with two poppet valves and cartridge check valve at port P The check valve is installed at port P of the 3/2-way poppet valve. Initial position: Descending Switching position: Lifting The load can be held in any position when the pump is turned off and the solenoid is energized.
symbol C 	3/2-way circuit with two poppet valves Initial position: Descending Switching position: Lifting The maintenance of position only depends on the stroke limit and the pressure at port P.	symbol U 	3/2-way circuit with a single poppet valve and cartridge check valve at port P The check valve is installed at port P of the 3/2-way poppet valve. Initial position: Lifting The load can be held in any position when the pump is turned off. Switching position: Descending
symbol C 	4/3-way (4/4-way) circuit with two poppet valves V1 and V2 in the initial position: Both ends of the cylinder are connected to the oil tank port. V2 in switching position: the piston moves to the left. V1 in switching position: the piston moves to the right. V1 and V2 in switching position: Both ends of the cylinder are connected to the pump port. The fast movement is possible when a single rod cylinder with an area ratio of 2:1 is used. Attention! When using single rod cylinders, the performance limit (double flow) of the valve and the maximum permissible working pressure (overpressure) must be taken into account!		
symbol U 	4/3-way (4/4-way) circuit with two poppet valves and cartridge check valve at port P of the 3/2-way poppet valve V1 and V2 in the initial position: the piston is locked externally to prevent oil flow. V2 in switching position: the piston moves to the right. V1 in switching position: the piston moves to the left. V1 and V2 in switching position: both ends of the cylinder are connected with the oil tank port. Attention! When using single rod cylinders, the performance limit (double flow) of the valve and the maximum permissible working pressure (overpressure) must be taken into account!		

Solenoid Operated Poppet Valve

Model: M-SED6...1XJ



- ◆ Size 6
- ◆ Maximum working pressure 350 bar
- ◆ Maximum working flow 25 L/min

Contents

Function description, sectional drawing	02-03
Models and specifications	04
Technical parameters	05
Characteristic curve	06
Characteristic limit	07
Component size	08-11
Application examples	12

Features

- Direct operated solenoid directional poppet valve
- Closed port without leakage
- Switching flexibility even in high-pressure state long periods
- Wet-pin DC solenoid with detachable coil (AC voltage available via rectifier)
- The coil can be rotated by 90°
- Replace the coil without opening the pressure chamber
- Individual electrical connection

Function description, sectional view

General:

The M-SED6 directional valve is solenoid operated directional poppet valve, it is used to control the opening, closing, and flow direction of oil.

The valve mainly consists of the valve body (1), solenoid (2) and closing element (4). The manual emergency operation (6) can control the valve when the solenoid is not energized.

01

Basic functions:

The initial position of the valve is determined by the setting of the spring (5). When the power is cut off, the "UK" type valve is opened, while the "CK" type valve is closed. The valve chamber (3) behind the closing element (4) is connected to the port P and sealed against the port T. Therefore, the valve is in a pressure balanced state related to the operating force (solenoid and the spring).

Due to the special closing element (4), the valve can work when the working pressure of ports P, A, and T up to 350bar, and flow in both directions (see symbols)!

In the initial position, the closing element (4) is pressed onto the valve seat (11) by the spring (5), and in the switching position, the solenoid (2) pushes it towards the valve seat (7). That results in a leak-free seal.

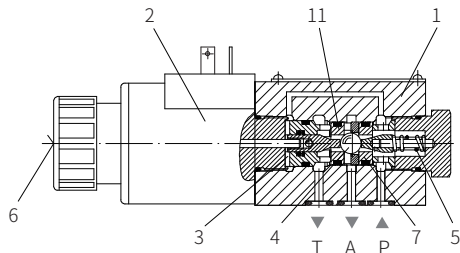

Model M-3SED6UK...1XJ/

Symbol "UK"

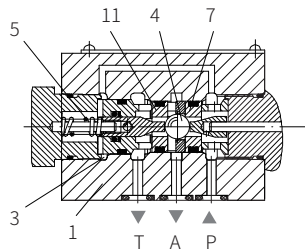
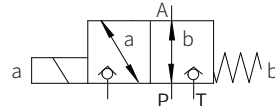

Model M-3SED6CK...1XJ/

Symbol "CK"

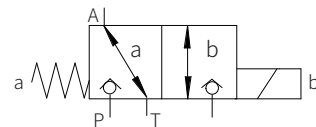

Function description, sectional view

To install a sandwich plate, the plus-1 plate under the 3/2-way directional poppet valve, then it can be used as a 4/2-way directional poppet valve.

Function of plus-1 plate:

Initial position:

The main valve does not work. The spring (5) holds the closing member (4) on the valve seat (11). The port P is closed, and port A is connected to port T. In addition, there is a control line over a large area from A to the control piston (8), which unloads to the tank. The pressure oil provided by the oil port P pushes the ball (9) to the valve seat (10), then P is connected to B and A to T.

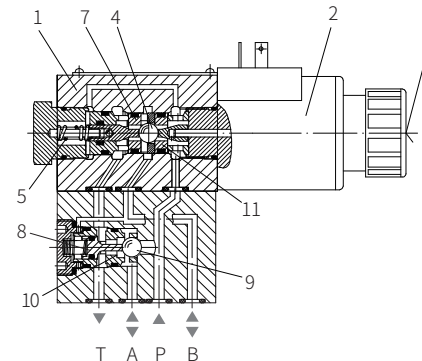

Model M-4SED6Y...1XJ/

Transition position:

When the main valve is operated, the closing element (4) overcomes the force of the spring (5) and presses on the valve seat (7). Therefore, the oil port T is closed, the ports P, A and B are connected to each other within a short time.

Switching position:

The port P is connected to A. The pressure oil from the pump acts on the large area of the control piston (8) through A, and the ball (9) is pushed to the valve seat (12). Therefore, B is connected to T and P to A.

The ball (9) in the plus-1 plate has a "positive cover switching function". In order to avoid a sudden increase of the pressure when using the single rod cylinder, the annular area of the cylinder must be connected to A.

Because of the using of the plus -1 plate and the different arrangement of the valve seat, the following situations may occur.

Symbol "D":

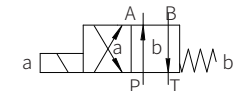

Symbol "Y":

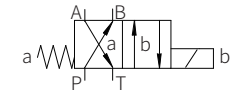

Cartridge throttle

Due to the working conditions limitations, it may occur that the flow exceeds the performance limit of the valve during the switching process, then the use of a throttle is required.

Example:

- Accumulator operation
- Used as a pilot valve with internal pilot oil supply

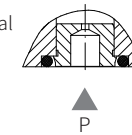

3/2-way poppet valve

The throttle is inserted into the port P of the directional valve.

4/2-way poppet valve

The throttle is inserted into the oil port P of the plus-1 plate.

Cartridge check valve

The cartridge check valve allows free flow from P to A and leak-free closure from A to P.

3/2-way poppet valve

The cartridge check valve is inserted into the oil port P of the directional valve.

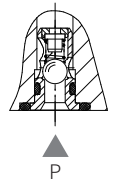

4/2-way poppet valve

The cartridge check valve is inserted into port P of the plus-1 plate.

Models and specifications

M - SED 6 - 1X J 350 C K4 *

3 way =3
4 way =4
poppet valve
size 6 =6

Working port	3	4	
functional symbols			
	•	-	= UK
	•	-	= CK
	-	•	= D
	-	•	= Y
	•		= Available

10 to 19 series (10 to 19 series installation and connection size unchanged) =1X
Rekith =J
Working pressure to 350bar =350
wet-pin solenoid with detachable coil =C
24VDC =G24
205VDC =G205²⁾

more information in text

sealing material
No code= NBR seals
V= FKM seals
(consult for other seals)

No code = without cartridge throttle and cartridge check valve
P= with cartridge check valve
B12= throttle Ø1.2mm
B15= throttle Ø1.5mm
B18= throttle Ø1.8mm
B20= throttle Ø2.0mm
B22= throttle Ø2.2mm

electrical connection
K4= no insert plug
Z5L= large right angle lamp plug

N9= with hidden manual emergency operation
No code= no manual emergency operation

2) When using AC power supply to DC solenoid, the voltage must be rectified by a rectifier (see table)
A large angle plug with integrated rectifier can be used for individual connection.

Technical parameters

Overview													
Installation position	Optional												
Environment temperature range	°C -30 to +50 (NBR seal) -20 to +50 (FKM seal)												
Weight	3/2-way valve kg 1.5 4/2-way valve kg 2.3												
Hydraulic													
Maximum working pressure	bar See characteristic limit												
Maximum flow	L/min 25												
Oil fluid	Mineral oil (HL, HLP) ¹⁾ in accordance with DIN 51524; Fast living organisms degraded oil according to VDMA 24568; HETG (Rapeseed oil) ¹⁾ ; HEPG(Polyethyleneglycol) ²⁾ ; HEES (Synthetic Fats) ²⁾												
Oil temperature range	-30 to +80 (NBR seal) -20 to +80 (FKM seal)												
Viscosity range	mm ² /s 2.8 to 500												
Cleanliness of oil ⁴⁾	The maximum allowable pollution level of oil is ISO4406 Class 20 / 18 / 15												
Electrical													
Voltage type	DC AC												
Voltage available ³⁾	V 24, 205 Only available via rectifier												
Allowable voltage tolerance	% ±10												
Power consumption	W 30												
Continuous power on time	% 100												
Switching time to ISO6403	See below table												
Switching frequency	times/hour 15000												
Protection type to DIN 40050	IP65 with plug installed and fixed												
Maximum coil temperature ⁵⁾	°C 150												
<p>1) For NBR seal and FKM seal. Electrical protective conductor(PE ⚡) must be connected properly as rules</p> <p>2) Only for FKM seal.</p> <p>3) Please inquire for special voltages</p> <p>4) The oil must meet the cleanliness degree requested by the components in the hydraulic system. Effective oil filtration can prevent failure and increase the service life of the components.</p> <p>Switching time tms (Installation position: Solenoids installed horizontally)</p>													
pressure P bar	Flow q _v L/min	DC Solenoid						AC Solenoid+Rectifier					
		Function symbols UK, CK, D, Y						Function symbols UK, CK, D, Y					
		t _{on} No tank pressure			t _{off}			t _{on} No tank pressure			t _{off}		
		U	C	D	Y	U/C	D/Y	U	C	D	Y	U/C	D/Y
70	25	45	40	50	50	10	15	45	40	45	40	40	40
140	25	60	40	50	50	10	15	55	40	55	40	40	40
210	25	60	45	60	50	10	15	60	45	60	45	40	40
280	25	60	45	60	50	10	15	15	45	65	45	40	40
315	25	65	45	65	50	10	15	15	45	65	45	40	40
350	25	65	45	65	50	10	15	15	45	65	45	40	40

Characteristic curve

(Measured when using HLP46, $\vartheta_{oil}=40^{\circ}\text{C} \pm 5^{\circ}\text{C}$)

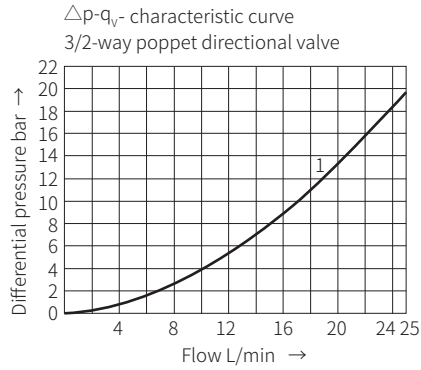

1 M - 3SED6 ^{UK}
CK ...; P to A and A to T

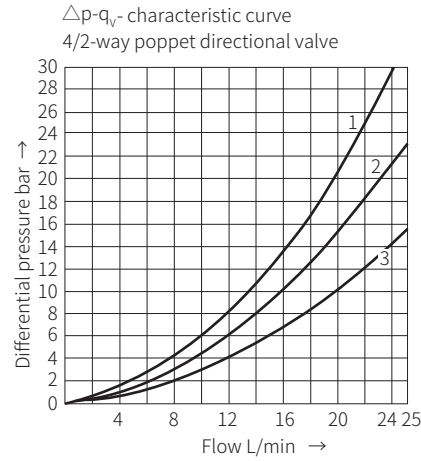
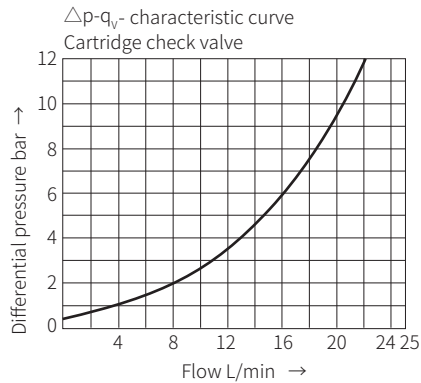

1 M - 4SED6 ^D
Y ...; A to T
2 M - 4SED6 ^D
Y ...; P to A
3 M - 4SED6 ^D
Y ...; B to T, P to B

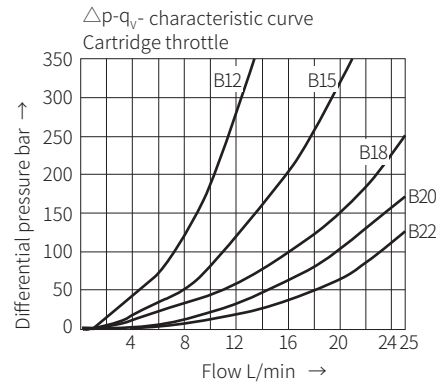

Characteristic limit

(Measured when using HLP46, $\vartheta_{oil}=40^{\circ}\text{C} \pm 5^{\circ}\text{C}$)

	Functional symbol	comment	Working pressure bar				Flow
			P	A	B	T	
Two-way circuit	"UK" 	The port P or T needs to be blocked by the customer when 2/2-way circuit used!	350	350		350	25
	"CK" 		350	350		350	25
Three-way circuit	"UK" 		350	350		350	25
	"CK" 		350	350		350	25
Four-way circuit (flow only in the direction of the arrow)	"D" 	3/2-way directional valve (model "UK") with plus-1 plate: $P \geq A \geq B \geq T$	350	350	350	P/A/B-40	25
	"Y" 	3/2-way directional valve (model "CK") with plus-1 plate: $P \geq A \geq B \geq T$	350	350	350	P/A/B-40	25

The characteristic limit is measured when the solenoid is at operating temperature, at 10% below the standard voltage and without tank preloading.

Component size

Size unit: mm

3/2-way poppet directional valve, Model "UK"

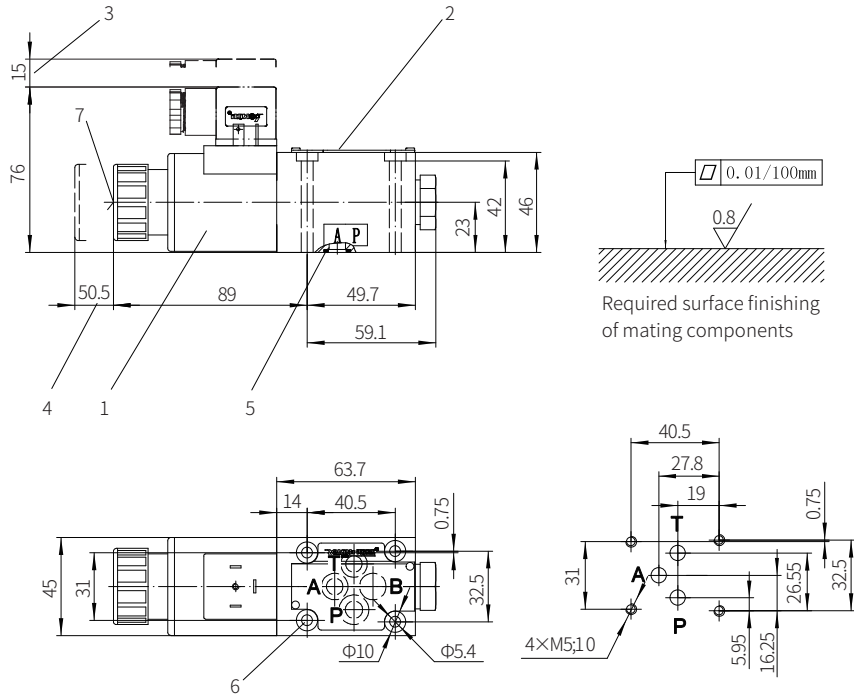

Valve fixing screw
M5x50-10.9 grade GB/T70.1-2000
Tightening torque $M_A=7.8\text{Nm}$

It must be ordered separately if connection subplate is needed.
Subplate model:
G341/01 (G1/4"); G341/02 (M14×1.5)
G342/01 (G3/8"); G342/02 (M18×1.5)
G502/01 (G1/2"); G502/02 (M22×1.5)

- 1 Solenoid
- 2 Name plate
- 3 Space required to remove the plug
- 4 Space required to remove solenoid nut
- 5 O-ring 9.25x1.78 (for oil port P, A, B, T)
O-ring 10x2 (for oil port P)
- 6 Screw connection hole
- 7 Hidden emergency button

Component size

Size unit: mm

3/2-way poppet directional valve, Model "CK"

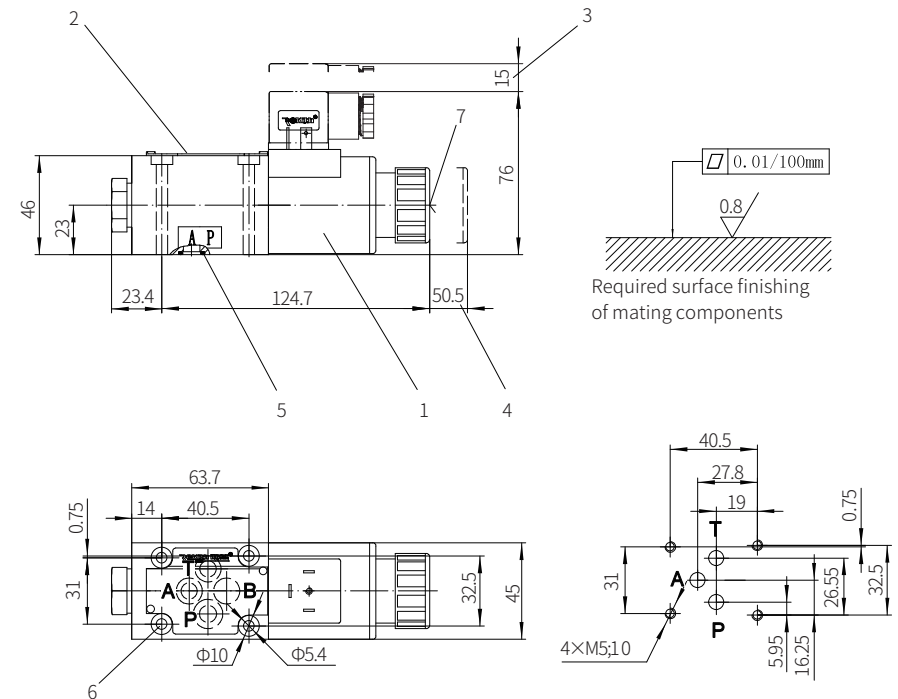

Valve fixing screw
M5x50-10.9 grade GB/T70.1-2000
Tightening torque $M_A=7.8\text{Nm}$

It must be ordered separately if connection subplate is needed.
Subplate model:
G341/01 (G1/4"); G341/02 (M14×1.5)
G342/01 (G3/8"); G342/02 (M18×1.5)
G502/01 (G1/2"); G502/02 (M22×1.5)

- 1 Solenoid
- 2 Name plate
- 3 Space required to remove the plug
- 4 Space required to remove solenoid nut
- 5 O-ring 9.25x1.78 (for oil port P, A, B, T)
O-ring 10x2 (for oil port P)
- 6 Screw connection hole
- 7 Hidden emergency button

Application examples

These examples only indicate some applications of the poppet valve but not include all functions.

	<p>2/2-way circuit Initial position: The flow is blocked and the pressure is held in the actuator even when the pump is turned off Switching position: The fluid flows freely and the maximum pressure is allowed.</p>		<p>2/2-way circuit Initial position: Lifting The maintenance of position only depends on the stroke limit and the pressure at port P. Switching position: Closed</p>
	<p>2/2-way circuit with two valves Initial position: The piston remains. Switching position: Move in both directions. The direction of movement depends on drives V1 and V2</p>		
<p>Symbol "CK"</p>	<p>3/2-way circuit Initial position: Side A remains logically closed Switching position: Side B remains logically closed</p>		
<p>Symbol "CK"</p>	<p>3/2-way circuit Initial position : Port P is closed, there is pressure at A and T, the piston of cylinder 1 moves to the right, and A is unloaded. The piston of cylinder 1 moves to the left. Switching position: Port T is closed, there is pressure at A and P. The piston of cylinder 2 moves to the left, and A is unloaded. The piston of cylinder 2 moves to the right.</p>		
<p>Symbol "2/2"+"UK"</p>	<p>4/2-way circuit with one 2/2-way and one 3/2-way poppet valve V1 and V2 in the initial position: the piston is blocked externally. V1 and V2 in switching position: the piston moves to the right. V1 in switching position and V2 in the initial position: the piston moves to the left. Both ends of the cylinder are connected with the pump port. Attention! When using single rod cylinders, the performance limit (double flow) of the valve and the maximum permissible working pressure (overpressure) must be taken into account!</p>		

Solenoid Operated Poppet Valve

Model: M-SED10...1XJ

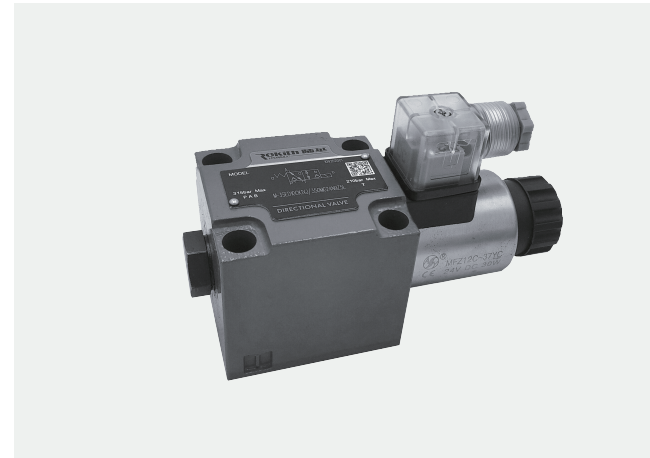

- ◆ Size10
- ◆ Maximum working pressure 350 bar
- ◆ Maximum working flow 40 L/min

Contents

Function description, sectional drawing	02-03
Models and specifications	04
Technical parameters	05
Characteristic curve	06
Characteristic limit	07
Component size	08-11
Application examples	12

Features

- Direct operated solenoid directional poppet valve
- Closed port without leakage
- Switching flexibility even in high-pressure state long periods
- Wet-pin DC solenoid with detachable coil (AC voltage available via rectifier)
- The solenoid coil can be rotated 90°
- Individual electrical connection
- Replacing the coil without opening the pressure chamber