

## Check Valve

Model: RVP...1XJ



- ◆ Size 6 to 40
- ◆ Maximum working pressure 315 bar
- ◆ Maximum working flow 600 L/min

### Contents

Function description, sectional drawing	02
Models and specifications	02
Characteristic curve	03
Component size	04

### Features

- Subplate mounting
- Leakage-free blocking in one direction

Any part of this brochure can not be reproduced, edited, copied and disseminated electronically in any way without authorization of Jiayite Hydraulics company. As the product is in constant development and innovation, the information in this brochure is not specific to the special conditions or applicability of a specific industry, thus Jiayite Hydraulics company is not responsible for any incomplete or inaccurate description generated.



## Function description, sectional drawing

The RVP type check valve is used to allow the oil to flow freely in one direction without allowing reverse flow.

The stroke of the valve core is limited by the spring seat, and the built-in spring keeps the valve core in a closed state.

The RVP type check valve is a conical valve structure with low pressure loss. It is mainly used at the outlet of the pump as a back pressure valve and bypass valve.

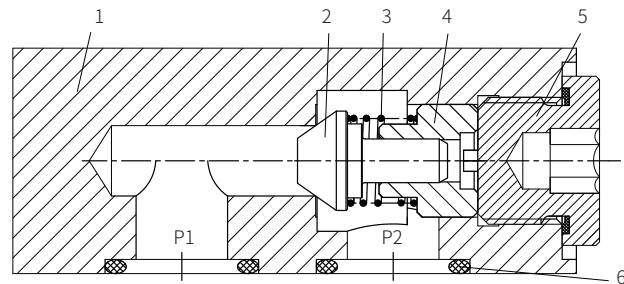

1 Valve body 2 Conical valve core 3 Spring 4 Spring seat 5 Plug 6 O ring

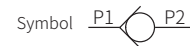

## Models and specifications

RV	P	1X	J	*
Check valve =RV	Subplate mounting =P			
Size 6	=6			
Size 8	=8			
Size 10	=10			
Size 12	=12			
Size 16	=16			
Size 20	=20			
Size 25	=25			
Size 30	=30			
Size 40	=40			
			J=	
				sealing material No code= NBR seals V= FKM seals (consult for other seals)
				Rekith
		1X=		Series 10 to 19 (10 to 19 series installation and connection size unchanged)

## Technical parameters

Size	6	8	10	12	16	20	25	30	40
Maximum working pressure (MPa)	31.5								
Cracking pressure of check valve (MPa)	0.05								
Pressure medium	Mineral oil(HL,HLP) <sup>1)</sup> in accordance with DIN51524; Fast living organisms Degraded oil according to VDMA 24568; HETG(Rapeseed oil) <sup>1)</sup> HEPG(Polyethylene glycol) <sup>2)</sup> ; HEES(synthetic ester) <sup>2)</sup>								
Oil temperature range (°C)	-20 to 80								
Viscosity range (mm <sup>2</sup> /s)	2.8 to 500								
Installation position	Optional								

## Characteristic curve

(Measured when using HLP46,  $\vartheta_{oil}=40^{\circ}\text{C}\pm 5^{\circ}\text{C}$ )

Flow direction: P1 to P2

The relationship between differential pressure  $\Delta P$  and flow Q

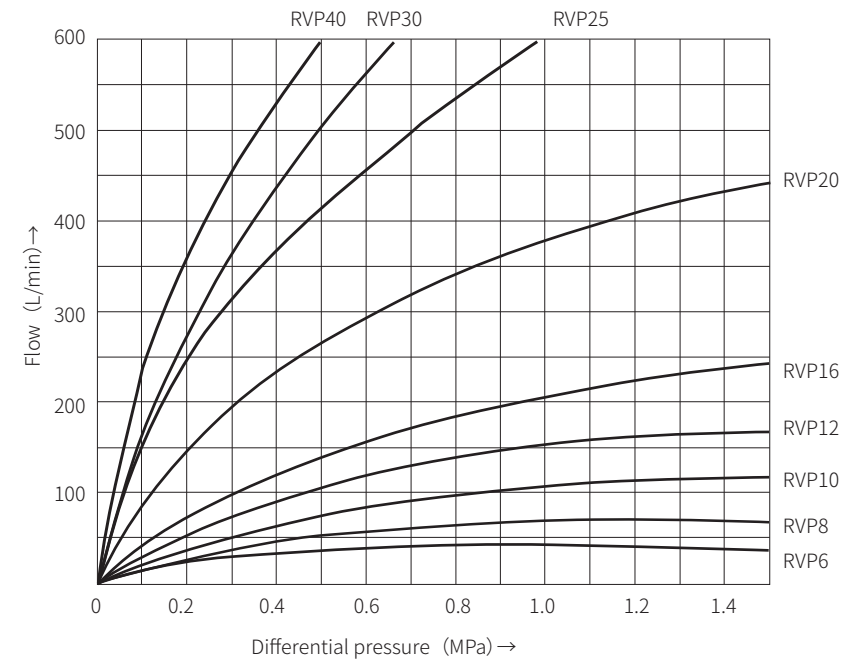

## Component size

Size unit: mm

Model RVP...1XJ/...

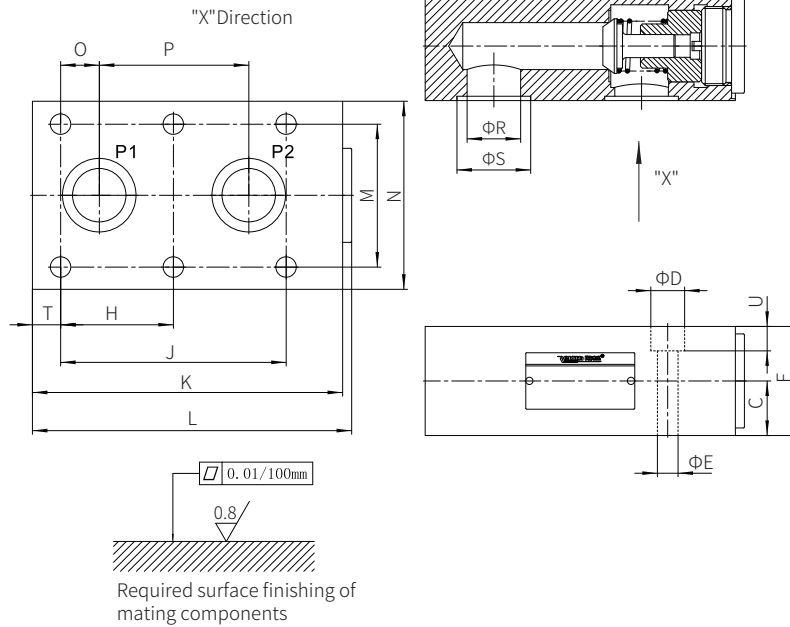

Size	C	D	E	F	H	J	K	L	M
RVP-6	11.5	11	6.6	23	-	19	41.5	46	28.5
RVP-8	13	11	6.6	24	-	35	63.5	67	33.5
RVP-10	13.5	11	6.6	27	-	33.5	70	74	38
RVP-12	16	11	6.6	32	-	38	80	84	44.5
RVP-16	22.5	14	9	45	38	76	104	109	54
RVP-20	26	14	9	50	47.5	95	127	132	60
RVP-25	29	18	11	58	60	120	165	170	76
RVP-30	37.5	20	14	75	71.5	143	186	192	92
RVP-40	50	20	14	100	67	133.5	192	198	111
Size	N	O	P	R	S	T	U	Weight (kg)	
RVP-6	41.5	1.6	16	6	12.2	6.4	8	0.26	
RVP-8	46	4.5	25.5	8	13.7	14.2	10	0.5	
RVP-10	51	4	25.5	10	15.7	18	7	0.80	
RVP-12	57.5	4	30	13	21.8	21	7	1.10	
RVP-16	70	11.4	54	17	24.5	12	12	2.25	
RVP-20	76.5	19	57	22	31.5	16	12	3.90	
RVP-25	100	20.6	79.5	28.5	39.2	15	13	6.70	
RVP-30	115	23.8	95	31	41	15	13	11.0	
RVP-40	140	25.5	89	45	54	16	18	17.0	

## Plug-in Check Valve

Model: M-SR...KE...1XJ



- ◆ Size 8 to 30
- ◆ Maximum working pressure 315 bar
- ◆ Maximum working flow 400 L/min

## Contents

Function description, sectional drawing	02
Functional symbols	02
Models and specifications	02
Technical parameters	03
Characteristic curve	04
Component size	05

## Features

- Insert into the manifolds blocks
- Reverse closing without leakage
- 6 optional cracking pressure