

1 - Directional valves

Contents

	Page
Solenoid operated poppet valve	
● M-SEW6...3XJ/Solenoid operated poppet valve	0179-0188
● M-SEW10...1XJ/Solenoid operated poppet valve	0189-0198
● M-SED6...1XJ/Solenoid operated poppet valve	0199-0210
● M-SED10...1XJ/Solenoid operated poppet valve	0211-0222
Hydraulic or electro-hydraulic directional valve	
● WEH/WH...5XJ/Hydraulic or electro-hydraulic directional valve	0223-0242
● WEH/WH...4X/6X/7XJ/Hydraulic or electro-hydraulic directional valve	0243-0268
Explosion-proof solenoid directional valve	
● GD-WE6...6XJ/Explosion-proof solenoid directional valve	0269-0276
● GD-WE10...3XJ/Explosion-proof solenoid directional valve	0277-0284
● GD-4WEMM6/10.../Explosion-proof solenoid operated directional valve with emergency handle	0285-0290
● G-M-SEW6...3XJ/Explosion-proof solenoid operated poppet valve	0291-0300
● G-M-SEW10...1XJ/Explosion-proof solenoid operated poppet valve	0301-0310
● G-WEH/WH...4X/6X/7XJ/Explosion-proof electro-hydraulic directional valve	0311-0334

Check Valve Model: S



- ◆ Size 6 to 30
- ◆ Maximum working pressure 450 bar
- ◆ Maximum working flow 450 L/min

Contents

Function description, sectional drawing	02
Models and specifications	02
Technical parameters	03
Characteristic curve	03
Component size	04-05

Features

- Leakage-free blocking in one direction
- Various cracking pressure
- Threaded connection
- Subplate mounting

Component size

Size unit: mm

Subplate mounting valve S...P...0J

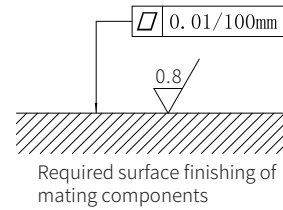
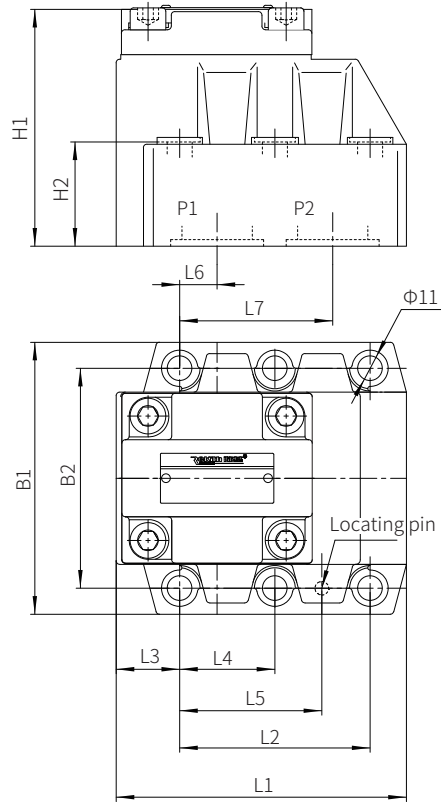

Subplate model:

size 10: G460/01 G460/02
G461/01 G461/02
size 20: G412/01 G412/02
G413/01 G413/02
size 30: G414/01 G414/02
G415/01 G415/02

Valve fixing screw:

size 10: 4-M10×40-10.9 GB/T70.1-2000
Tightening torque $M_A=60\text{Nm}$
size 20: 4-M10×50-10.9 GB/T70.1-2000
Tightening torque $M_A=60\text{Nm}$
size 30: 4-M10×70-10.9 GB/T70.1-2000
Tightening torque $M_A=60\text{Nm}$

Size	B1	B2	L1	L2	L3	L4	L5	L6	L7	H1	H2	O-ring for ports P1, P2
10	85	66.7	78	42.9	17.8	-	31.8	7.1	35.7	64	21	17.12×2.62
20	102	79.4	101	60.3	23	-	44.5	11.1	49.2	91	31.5	28.17×3.53
30	120	96.8	128	84.2	28	42.1	62.7	16.7	67.5	104.5	46	34.52×3.53

Component size

Size unit: mm

Threaded connection valve S...A...J/

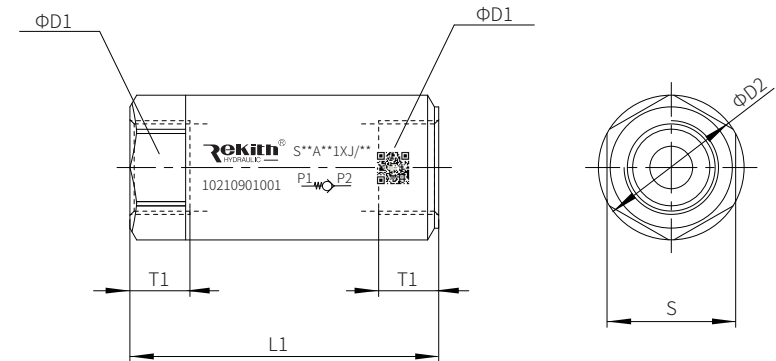

Size	6	8	10	15	20	25	30
D1	G	G1/4"	G3/8"	G1/2"	G3/4"	G1"	G1-1/4"
	M	M14×1.5	M18×1.5	M22×1.5	M27×2	M33×2	M42×2
D2	22.5	28	34	42	52	68	74.5
L1	58	58	72	85	98	120	132
T1	12	12	14	16	18	20	22
S	19	24	30	36	46	60	65
Weight (Kg)	0.1	0.2	0.3	0.5	1	2	2.5