

Application examples

These examples only indicate some applications of the poppet valve but not include all functions.

	<p>2/2-way circuit Initial position: The flow is blocked and the pressure is held in the actuator even when the pump is turned off. Switching position: The fluid flows freely and the maximum pressure is allowed.</p>		<p>2/2-way circuit Initial position: Lifting The maintenance of position only depends on the stroke limit and the pressure at port P. Switching position: Closed.</p>
			<p>2/2-way circuit with two valves Initial position: The piston remains. Switching position: Move in both directions. The direction of movement depends on drives V1 and V2.</p>
			<p>3/2-way circuit Initial position: Side A remains logically closed Switching position: Side B remains logically closed</p>
<p>Symbol "CK"</p>			<p>3/2-way circuit Initial position: Port P is closed, there is pressure at A and T. The piston of cylinder 1 moves to the right, and A is unloaded. The piston of cylinder 1 moves to the left. Switching position: Port T is closed, there is pressure at A and P. The piston of cylinder 2 moves to the left, and A is unloaded. The piston of cylinder 2 moves to the right.</p>
<p>Symbol "2/2"+"UK"</p>			<p>4/2-way circuit with one 2/2-way and one 3/2-way poppet valve V1 and V2 in the initial position: the piston is blocked external. V1 and V2 in switching position: the piston moves to the right. V1 in switching position and V2 in the initial position: the piston moves to the left. Both ends of the cylinder are connected with the pump port. Attention! When using single rod cylinders, the performance limit (double flow) of the valve and the maximum permissible working pressure (overpressure) must be taken into account!</p>

Hydraulic or Electro-hydraulic Directional Valve

Model: WEH/WH...5XJ

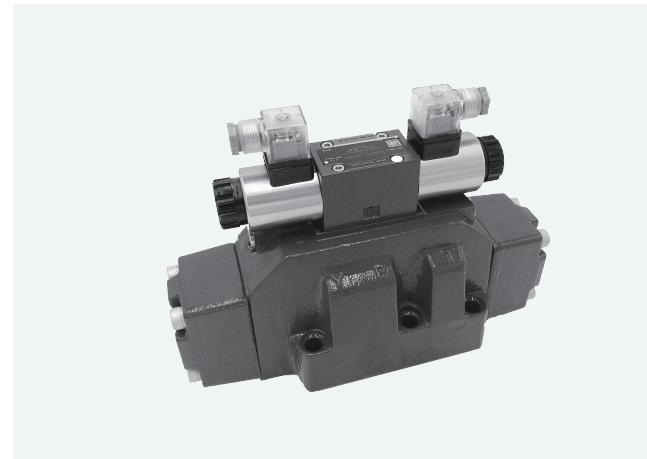

- ◆ Size 10~32
- ◆ Maximum working pressure 350 bar
- ◆ Maximum working flow 1100 L/min

Contents

Function description, sectional drawing	02 - 04
Models and specifications	05
Functional symbols	06-08
Technical parameters	09-10
Characteristic curve	11-13
Characteristic limit	11-13
Switching time adjustment, pressure reducing valve and pre-load valve	14
Component size	15-20

Features

- Mainly used to control the opening, closing and direction of liquid flow
- Electro-hydraulic operation (WEH)
- Hydraulic operation (WH)
- Subplate mounting
- The mounting surface according to DIN24340 form A and ISO4401
- Spring or hydraulic centered
- Spring or hydraulic return to initial position
- Wet-pin DC or AC solenoid
- Optional manual emergency operation
- Individual or central electrical connection
- Optional switching time adjustment
- Optional pre-load valve in port P of the main valve
- Auxiliary component, optional
- Stroke adjustment of main spool
- Stroke adjustment or end position sensor
- Inductive or mechanical limit switch (proximity type) of the main spool

Function description, sectional drawing

Directional valve model WEH

The WEH directional valve is a directional spool valve with electro-hydraulic operation. It is used to control the opening, closing and direction of the liquid flow. The valve mainly consists of valve body (1), main control spool (2), main valve with one or two reset springs (3.1) and (3.2), pilot valve (4) with one or two solenoids "a" (5.1) and "b" (5.2). The main control spool is held in the neutral or initial position by the springs or pressure. For the valve with spring-centered, the two spring chambers (6) and (8) are connected to the oil tank through the pilot valve in the initial position. The pilot valve (4) is supplied with oil through the control line (7). The control oil can be supplied internally or externally (externally via port X). The main control spool (2) is hydraulically operated by the pilot valve (4). Due to the operating of the pilot valve on one end of the main control spool, the spool moves to the operation position, then the valve opens in the operation direction and the fluid flows from P to A and B to T or P to B and A to T. The control oil can be drained internally or externally. An optional manual emergency operation (9) can move the control spool (10) in the pilot valve (4) when the solenoid is not energized.

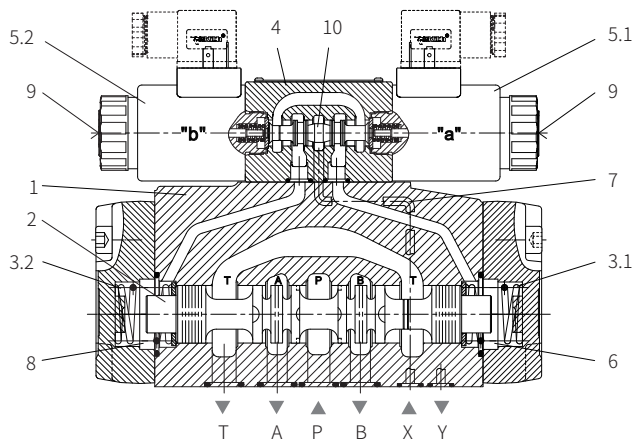

Directional valve model 4WEH.

Directional valve model WH

The WH directional valve is a hydraulically operated directional spool valve. It is used to control the opening, closing and direction of liquid flow. The valve mainly consists of valve body (1), main control spool (2), one or two reset springs (3.1) and (3.2) with spring centered or spring return functions, and control cover (11). The main control spool is operated by hydraulic directly. The spool is held in the neutral or initial position by springs or hydraulic pressure. The control oil is supplied and drained externally. For the 4/3-way valve with spool spring centered, the main control spool (2) is held in the neutral position by two centered springs. The two spring chambers (6, 8) are connected to the oil ports X and Y through the control cover (11). When one end of the main control spool (2) is pressurized, the spool moves to the working position, thereby connecting the corresponding oil circuit.

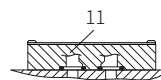

Model 4WH...

Function description, sectional drawing

4/3-way directional valve with hydraulic centered of main valve, model WEH..H/

In this structure, the pressure oil acts on both end surfaces of the main control spool (2). The centering sleeve (10) locates the main control spool (2) and keeps it in the middle position. If one end of the main control spool (2) is unloaded, the main control spool (2) moves to the working position under the pressure from the other end, thereby changing the direction of the oil flow. The unloaded control spool face displaces the returning pilot oil into port Y externally through the pilot valve (4). The oil is drained internal from port L to the tank directly.

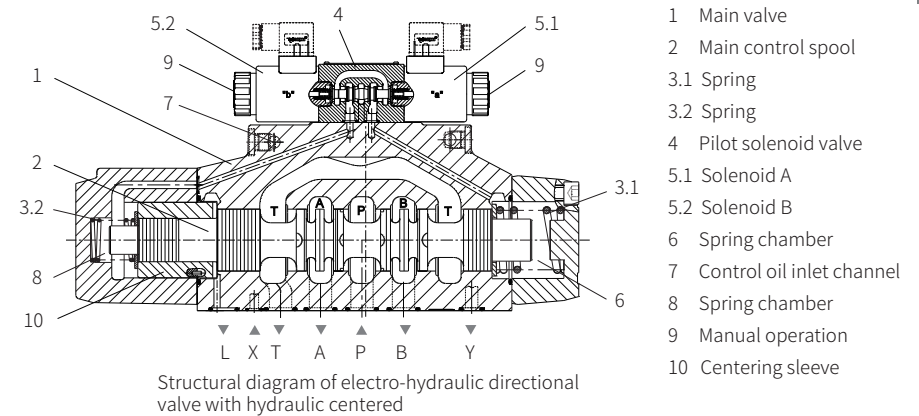

Structural diagram of electro-hydraulic directional valve with hydraulic centered

● Model WEH16

◆ Internal supply and drain:

The small end of pin (4) on the top of the main valve is installed toward to the end cover without plug (5).

◆ External supply and drain:

The large end of pin (4) on the top of the main valve is installed toward to end cover with plug (5).

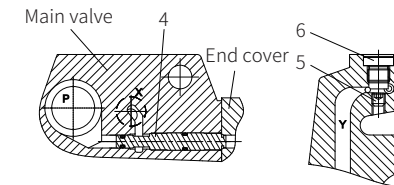
structure diagram of model WEH16...5XJ/
supply and drain

Functional symbols

Detailed and simplified symbols for 3-position directional valves

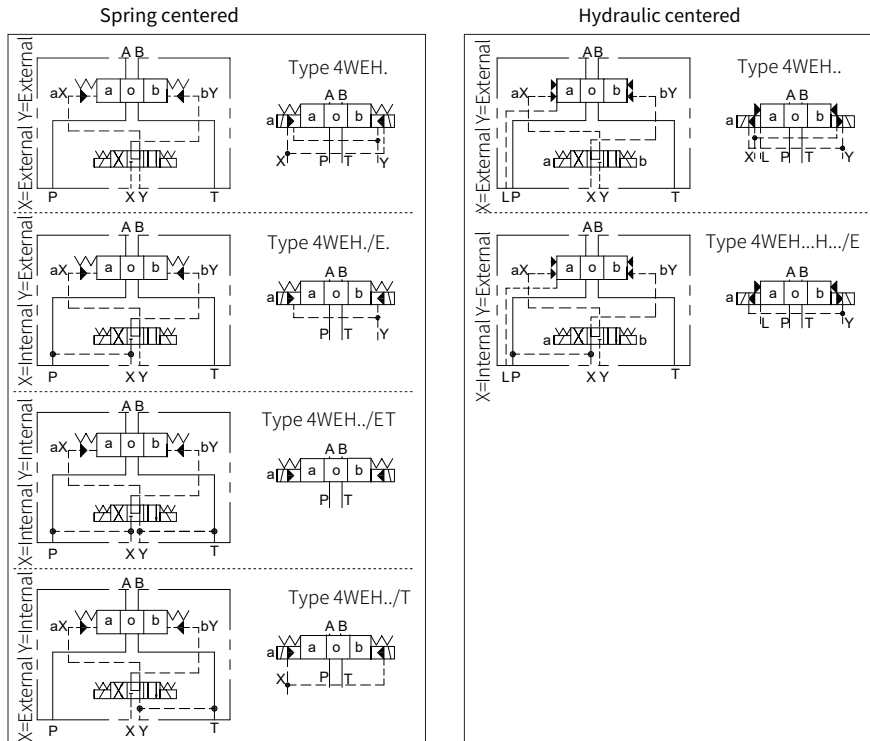

Spring return valves
(the solenoid at end A or B of the 2-position valve derived from the 3-position valve)

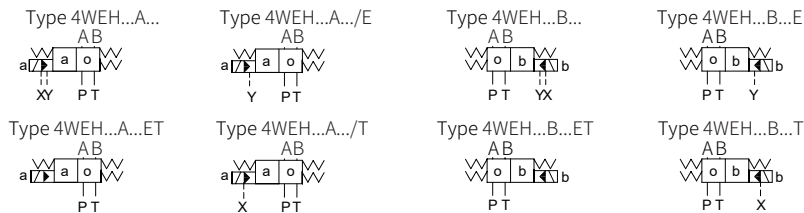

Hydraulic return valves
(the solenoid at end A or B of the 2-position valve derived from the 3-position valve)

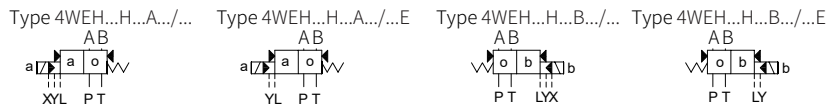

Functional symbols

Functional symbols of 3-position valves

3-position valve

3-position valve model	Functional symbol	Transition function
4WEH...E.../... E		
4WEH...F.../... F		
4WEH...G.../... G		
4WEH...H.../... H		
4WEH...J.../... J		
4WEH...L.../... L		
4WEH...M.../... M		
4WEH...P.../... P		
4WEH...Q.../... Q		
4WEH...R.../... R		
4WEH...S.../... S		
4WEH...T.../... T		
4WEH...U.../... U		
4WEH...V.../... V		
4WEH...W.../... W		

2-position valve derived from 3-position valve

2-position valve model (Solenoid at end A)	Functional symbol	2-position valve model (Solenoid at end B)	Functional symbol
4WEH...EA.../... (Solenoid at end A)		4WEH...EB.../... (Solenoid at end B)	
4WEH...FA.../... (Solenoid at end A)		4WEH...FB.../... (Solenoid at end B)	
4WEH...GA.../... (Solenoid at end A)		4WEH...GB.../... (Solenoid at end B)	
4WEH...HA.../... (Solenoid at end A)		4WEH...HB.../... (Solenoid at end B)	
4WEH...JA.../... (Solenoid at end A)		4WEH...JB.../... (Solenoid at end B)	
4WEH...LA.../... (Solenoid at end A)		4WEH...LB.../... (Solenoid at end B)	
4WEH...MA.../... (Solenoid at end A)		4WEH...MB.../... (Solenoid at end B)	
4WEH...PA.../... (Solenoid at end A)		4WEH...PB.../... (Solenoid at end B)	
4WEH...QA.../... (Solenoid at end A)		4WEH...QB.../... (Solenoid at end B)	
4WEH...RA.../... (Solenoid at end A)		4WEH...RB.../... (Solenoid at end B)	
4WEH...SA.../... (Solenoid at end A)		4WEH...SB.../... (Solenoid at end B)	
4WEH...TA.../... (Solenoid at end A)		4WEH...TB.../... (Solenoid at end B)	
4WEH...UA.../... (Solenoid at end A)		4WEH...UB.../... (Solenoid at end B)	
4WEH...VA.../... (Solenoid at end A)		4WEH...VB.../... (Solenoid at end B)	
4WEH...WA.../... (Solenoid at end A)		4WEH...WB.../... (Solenoid at end B)	

Functional symbols

Detailed and simplified symbols for 2-position directional valves

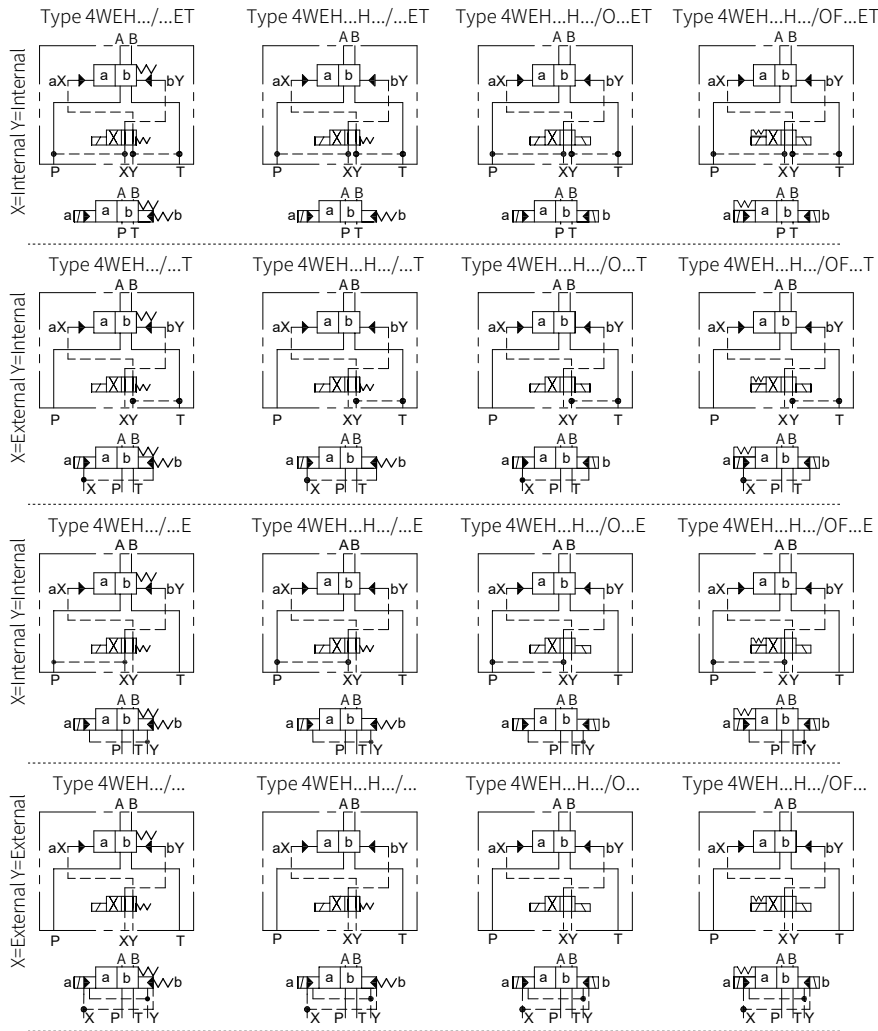

Function symbols of 2-position valves

Spool valve function:	C	D	K	Z	Y
Spool valve function symbol:					
Transition function:					

Technical parameters

Size	16	25	32	
Maximum working pressure				
Oil ports P, A, B (MPa)	35	35	35	
Oil port T				
External Y port pilot oil drain (MPa)	25	25	25	
Internal Y port pilot oil drain (MPa)		21 DC	16 AC	
Oil port Y		21 DC		
External pilot oil drain		16 AC		
For 4WH type (MPa)		25 (size 16, 25, 32)		
Maximum pilot pressure (MPa)		25 (size 16, 25, 32)		
Minimum pilot pressure (MPa)		H-4W...		
-Pilot oil supply X external				
-Pilot oil supply X internal (Not for spool C, F, G, H, P, T, V, Z, S ²)				
Spring centered 3-position valve (MPa)	1.4	1.3	0.85	
Pressure centered 3-position valve (MPa)	1.4	1.8	0.85	
Spring centered 2-position valve (MPa)	1.4	1.3	1.0	
Pressure centered 2-position valve (MPa)	1.4	0.8	0.5	
Pilot oil supply X internal (for spool C, F, G, H, P, T, V, Z, S ²)	0.45 ⁴⁾	0.45 ⁴⁾	0.45 ⁴⁾	
<p>1) In a 3-position valve, pressure centered only possible if: Ppilot ≥ 2xPtank + Ppilot min.</p> <p>2) Spool S only for size 16.</p> <p>3) For the spools C, F, G, H, P, T, V, Z, the internal pilot oil supply is only possible if the flow from P to T in the central position (for 3-position valve) or when the valve moves through the central position (for 2-position valve) is large enough to ensure the pressure differential as 0.65MPa from P to T.</p> <p>4) For the spools C, F, G, H, P, T, V, Z, S-via the pre-load valve or correspondingly large flow.</p>				
Hydraulic oil	Mineral hydraulic oil or phosphate ester hydraulic oil			
Temperature range (°C)	-30 to +80 (NBR seal) -20~+80 (FKM seal)			
Viscosity range (mm ² /s)	2.8 to 500			
Cleanliness of oil	The maximum allowable pollution level of oil is NAS1638 Class 9, so we recommend a filter with the minimum filtration accuracy β10 ≥ 75			
Pilot oil volume during switching process				
3-position valve spring centered (cm ³)	5.72	14.2	29.4	
2-position valve (cm ³)	11.45	28.4	58.8	
3-position valve hydraulic centered (cm ³)	WH	WEH	WH	
from neutral position to position "a" (cm ³)	2.83	2.83	7.15	
From position "a" to neutral position (cm ³)	5.72	5.72	14.18	
From neutral position to position "b" (cm ³)	5.72	5.72	14.15	
from position "b" to neutral position (cm ³)	8.55	8.55	19.88	
Pilot oil flow for shortest switching time (L/min)	about 35	about 35	about 45	
Weight	Valve with one solenoid (kg)	about 8.5	about 17.6	about 40.5
	Valve with two solenoid, spring centered (kg)	about 8.9	about 18.0	about 41.0
	Valve with two solenoid, hydraulic centered (kg)	about 8.9	about 19.0	about 41.0
	Valve with hydraulic control (kg)	about 7.3	about 16.5	about 39.5
	Switching time adjustment (kg)		about 0.8	
Pressure reducing valve (kg)		about 0.4		
Installation position	Optional, except for the hydraulic return valve C, D, K, Z, Y installed horizontal			

Technical parameters

Switching time (refers to the time from the solenoid closing to the main valve fully opening.)												
Size 16	Switching time for valve from neutral position to operating position (for DC (=) and AC (~) operation)											
	at pilot pressure (MPa)											
	~7=			~15=			~25=					
	3-position valve-spring centered (ms)											
	2-position valve (ms)											
	3-position valve Solenoid operated - hydraulic centered (ms)											
	Switching time for valve from operating position to static position											
3-position valve (ms)												
2-position valve (ms)												
3-position valve From- hydraulic centered (ms)												
Size 25	Switching time for valve from neutral position to operating position (for DC (=) and AC (~) operation)											
	at pilot pressure (MPa)											
	~7=			~14=			~21=			~25=		
	3-position valve-spring centered (ms)											
	2-position valve (ms)											
	3-position valve Solenoid operated - hydraulic centered (ms)											
	Switching time for valve from operating position to static position											
3-position valve (ms)												
2-position valve (ms)												
3-position valve - hydraulic centered From- (ms)												
Size 32	Switching time for valve from neutral position to operating position (for DC (=) and AC (~) operation)											
	at pilot pressure (MPa)											
	~5=			~15=			~25=					
	3-position valve-spring centered (ms)											
	2-position valve (ms)											
	3-position valve Solenoid operated - hydraulic centered (ms)											
	Switching time for valve from operating position to static position											
3-position valve (ms)												
2-position valve (ms)												
3-position valve From- hydraulic centered (ms)												

01

Characteristic curve

Model 4WEH16...(Measured at $v_{oil}=41\text{mm}^2/\text{s}$ and $t=50^\circ\text{C}$)

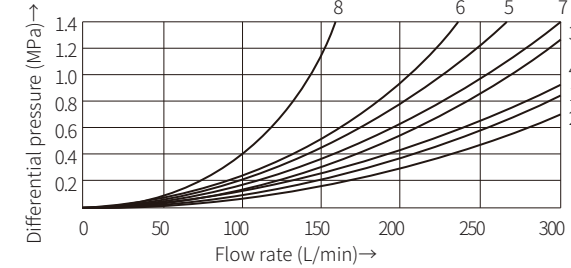

Spool	Working position				
	P-A	P-B	A-T	B-T	P-T
E, D, Y	1	1	1	3	-
F, P	2	2	3	3	-
G, T	5	1	3	7	6
H, C, Q, V, Z	2	2	3	3	-
J, K, L	1	1	3	3	-
M, W	2	2	4	3	-
R	2	2	4	-	-
U	1	1	4	7	-
S	4	4	4	-	8

01

Characteristic limit

Model 4WEH16...(Measured at $v_{oil}=41\text{mm}^2/\text{s}$ and $t=50^\circ\text{C}$)

Spool	Working pressure(MPa)				
	7	14	21	28	35
Main valve spring return ¹⁾					
C, D, K, Z, Y	300	300	300	300	300
Main valve spring return ²⁾					
C	300	300	300	300	300
D, Y	300	270	260	250	230
K	300	250	240	230	210
Z	300	260	190	180	160
Main valve hydraulic return					
HC, HD, HK	300	300	300	300	300
HZ, HY	300	300	300	300	300

Spool	Working pressure(MPa)					with pre-load valve and X port internal supply
	7	14	21	28	35	
Main valve spring return ¹⁾						
E, H, J, L, MQ, U, W, R	300	300	300	300	300	Spools F, G, H P and S in general
F, P	300	250	180	170	150	
G, T	300	300	240	210	190	
S	300	300	300	250	220	
V	300	250	210	200	180	
Pressure centered (minimum pilot pressure 1.6MPa)						
All spools	300	300	300	300	300	Spool approx. to 160L/min

Notice:

When using a 4/3-way valve with pressure centered in the main spool which exceeds the given performance limits, a higher pilot pressure is required. Therefore, if the pressure is 35MPa and the flow is 300L/min in the circuit, the pilot pressure of 1.6MPa is required. The maximum flow of the valve only depends on the acceptable pressure drop through the valve.

- 1)The given flow value can be achieved when the minimum pilot pressure of 1.2MPa exists.
- 2) The given flow value is limiting the value at which the reset spring can return the valve when the pilot pressure decreases.

Characteristic curve

Model 4WEH25...(Measured at $\dot{v}_{oil}=41\text{mm}^2/\text{s}$ and $t=50^\circ\text{C}$)

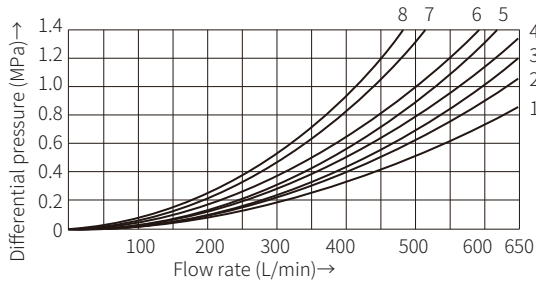

Spool	Working position				Spool	Working position			
	P-A	P-B	A-T	B-T		P-A	P-B	A-T	B-T
E	1	1	1	3	P	4	1	1	5
F	1	4	3	3	Q	2	2	3	5
G	3	1	2	4	Z	1	1	1	-
H	4	4	3	4	U	2	1	1	6
J	2	2	3	5	V	4	4	3	6
L	2	2	3	3	W	1	1	1	3
M	4	4	1	4	T	3	1	2	4

Characteristic limit

Model 4WEH25...(Measured at $\dot{v}_{oil}=41\text{mm}^2/\text{s}$ and $t=50^\circ\text{C}$)

Allowable flow of 2-position valve (L/min)						with pre-load valve and X port internal supply	Allowable flow of 3-position valve (L/min)						with pre-load valve and X port internal supply
Spool	Working pressure(MPa)						Spool	Working pressure(MPa)					
	7	14	21	28	35			7	14	21	28	35	
Main valve spring return ¹⁾						Spools C and Z approx. to 180 L/min	spring centered						Spools F, G, HP and T approximately to 180L/min
C, D, K, Z, Y							700	700	700	700	700		
Main valve spring return ²⁾							E, L, M	700	700	700	650		
C							Q, U, W	400	400	400	400		
D, Y							G/T	400	400	400	300		
K							F	650	550	430	330		
Z							H	700	650	550	400		
Main valve hydraulic return							J	700	700	650	520		
HC, HD, HK							P	650	550	430	330		
HZ, HY							V	650	550	400	310		
HC.../O						R	700	700	700	650			
HD.../O						Pressure centered (minimum pilot pressure 1.8MPa)							
HK.../O						E/F/H/J	700	700	700	650			
HZ.../O						L/M/P/Q	700	700	700	650			
HC.../OF						R/U/V/W	700	700	700	650			
HD.../OF						G/T	400	400	400	400			
HK.../OF						When the pilot pressure higher than 3MPa							
HZ.../OF						G/T	700	700	700	700			

- 1) The given flow value can be achieved when the minimum pilot pressure of 1.3MPa exists.
- 2) The given flow value is limiting the value at which the reset spring can return the valve when the pilot pressure decreases.

Characteristic curve

Model 4WEH32...(Measured at $\dot{v}_{oil}=41\text{mm}^2/\text{s}$ and $t=50^\circ\text{C}$)

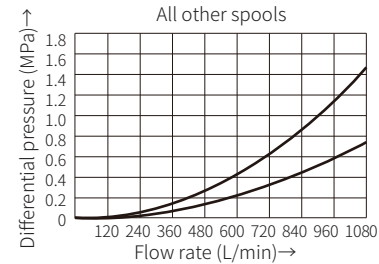
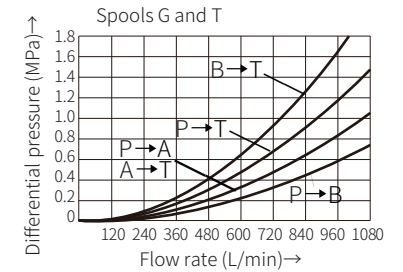
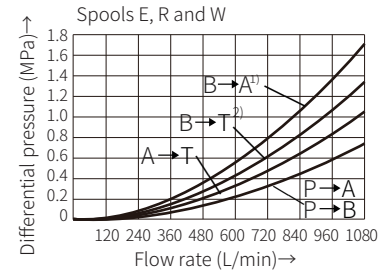

- 1) Only for spool R
- 2) Not for spool R

Characteristic limit

Model 4WEH32...(Measured at $\dot{v}_{oil}=41\text{mm}^2/\text{s}$ and $t=50^\circ\text{C}$)

Allowable flow of 2-position valve (L/min)						with pre-load valve and X port internal supply	Allowable flow of 3-position valve (L/min)						with pre-load valve and X port internal supply					
Spool	Working pressure(MPa)						Spool	Working pressure(MPa)										
	7	14	21	28	25			7	14	21	28	25						
Main valve spring return ¹⁾						Spool Z approx to 180L/min	Main valve spring return ¹⁾						Spools F, G, H, P and T approximately to 180L/min					
C, D, K, Z, Y							1100	1040	860	750	680							
Main valve spring return ²⁾							E, H, J, L, M	1100	1040	860	750	680						
C							Q, U, W, R	900	900	800	650	450						
D, Y							G, T, H, F, P	900	900	800	650	450						
K							V	1100	1000	680	500	450						
Z							Pressure centered (minimum pilot pressure 0.85MPa)											
Main valve hydraulic return							All spools							1100	1040	860	750	680
HC, HD, HK							Spool Z approx to 180L/min											
HZ, HY							1100	1040	860	750	680							

Notice:
When using a 4/3-way valve with pressure centered in the main spool which exceeds the given performance limits, a higher pilot pressure is required. Therefore, if the pressure is 35MPa and the flow is 300L/min in the circuit, the pilot pressure of 1.5MPa is required. The maximum flow of the valve only depends on the acceptable pressure drop through the valve.

- 1) The given flow value can be achieved when the minimum pilot pressure of 1.0MPa exists.
- 2) The given flow value is limiting the value at which the reset spring can return the valve when the pilot pressure decreases.

Switching time adjustment, pressure reducing valve and pre-load valve

Switching time adjustment

To control the switching time of the main valve (1), a double throttle check valve (12) is installed between the pilot valve and the main valve. Conversion from meter-in control (13) to meter-out control (14): Remove the pilot valve (4) but retain the O-ring support plate (15), turn the throttle check valve around its longitudinal axis and reassemble it on the mounting surface, install the pilot valve (4). Tightening torque $M_A=9Nm$ for fixing screw (16).

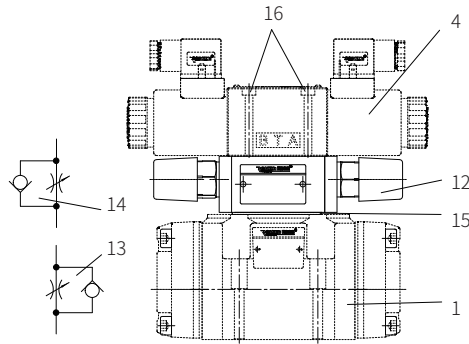

Model 4WEH.../S or S2

Pressure reducing valve "D3"

The pressure reducing valve (17) must be used if the pilot pressure exceeds 25MPa. The secondary pressure should be maintained at 4.5MPa. When using the pressure reducing valve D3, it must install a plug-in throttle B10 in port P of the pilot valve. Tightening torque $M_A=9Nm$ for fixing screw (16).

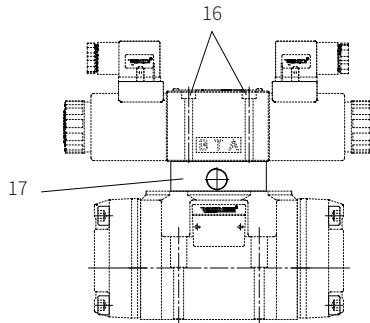

Model 4WEH.../.../D3

Pre-load valve

In the valve with pressureless bypass and internal pilot oil supply, a pre-load valve (18) is installed in port P of the main valve to built up the minimum pilot pressure.

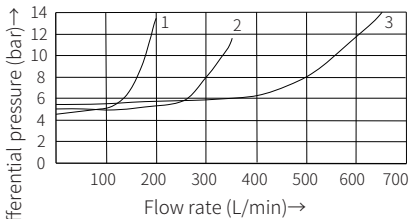

- 1 Size 16
- 2 Size 25
- 3 Size 32

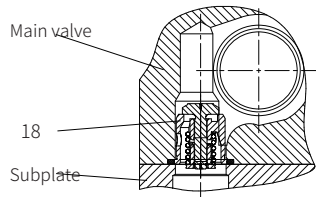

Model
4WEH16...-5X/.../P4.5
4WEH25.../.../P4.5
4WEH32.../.../P4.5

Component size

Size unit: mm

WEH16...5XJ/...

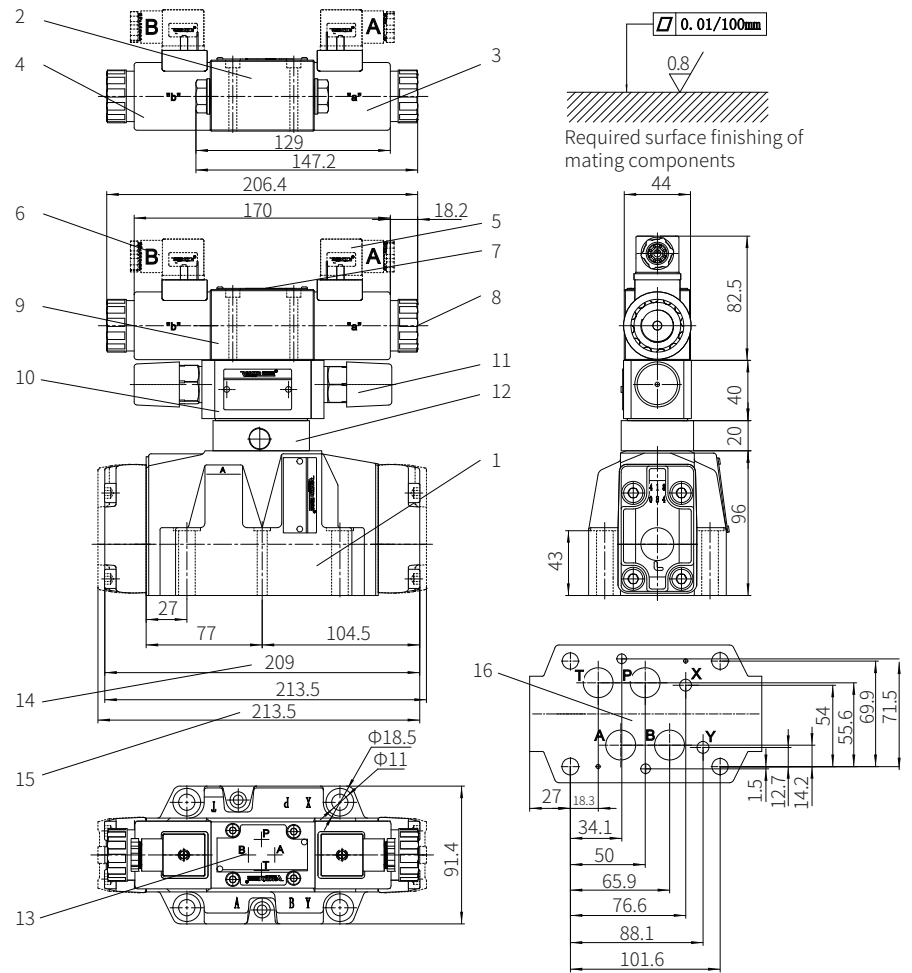

- 1 Main valve
- 2 2-position valve with one solenoid and plug Z4
- 3 Solenoid a
- 4 Solenoid b
- 5 Gray plug (or transparent plug)
- 6 Black plug (or transparent plug)
- 7 Name plate of pilot valve
- 8 Manual emergency operation
- 9 2-position or 3-position valve with two solenoids and plug Z4
- 10 Switching time adjustment
- 11 Adjustment bolt
- 12 Pressure reducing valve
- 13 Port layout of main valve (valve mounting surface)
- 14 Size of 3-position valve with spring centered
- 15 Size of 2-position valve with spring centered
- 16 Main valve connection diagram
- Valve fixing screw
2-M6x55-10.9 grade GB/T70.1-2000
Tightening torque $M_A=13.7Nm$
- 4-M10x60-10.9 grade GB/T70.1-2000
Tightening torque $M_A=60Nm$

Component size

Size unit: mm

Dimension of additional devices for model WEH16

The installation range of the stroke adjustment is 10mm. The stroke limiter is used to adjust the stroke of the main spool. Loosen the lock nut and rotate the adjusting rod clockwise, the stroke of the main spool will be shortened (the adjustment must be carried out without pressure in the control chamber)

1 turn = 1.5mm stroke

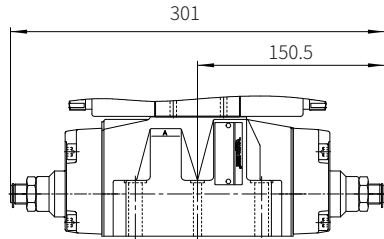
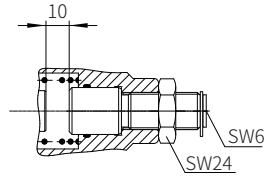

Stroke adjustment installed on the ends A and B of the main valve.../10

Stroke adjustment installed on the end A of the main valve.../11

Stroke adjustment installed on the end B of the main valve.../12

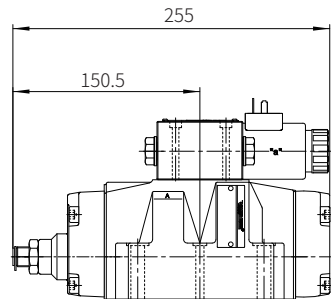

Stroke adjustment installed on the end A of the main valve.../11

(2-position valve, symbols C, D, K, Z)

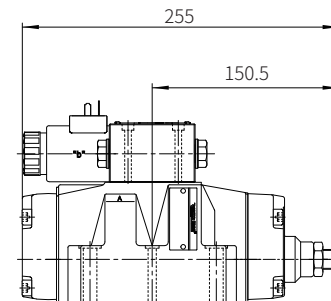

Stroke adjustment installed on the end B of the main valve.../12

(2-position valve, symbol Y)

Component size

Size unit: mm

WEH25...5XJ/...

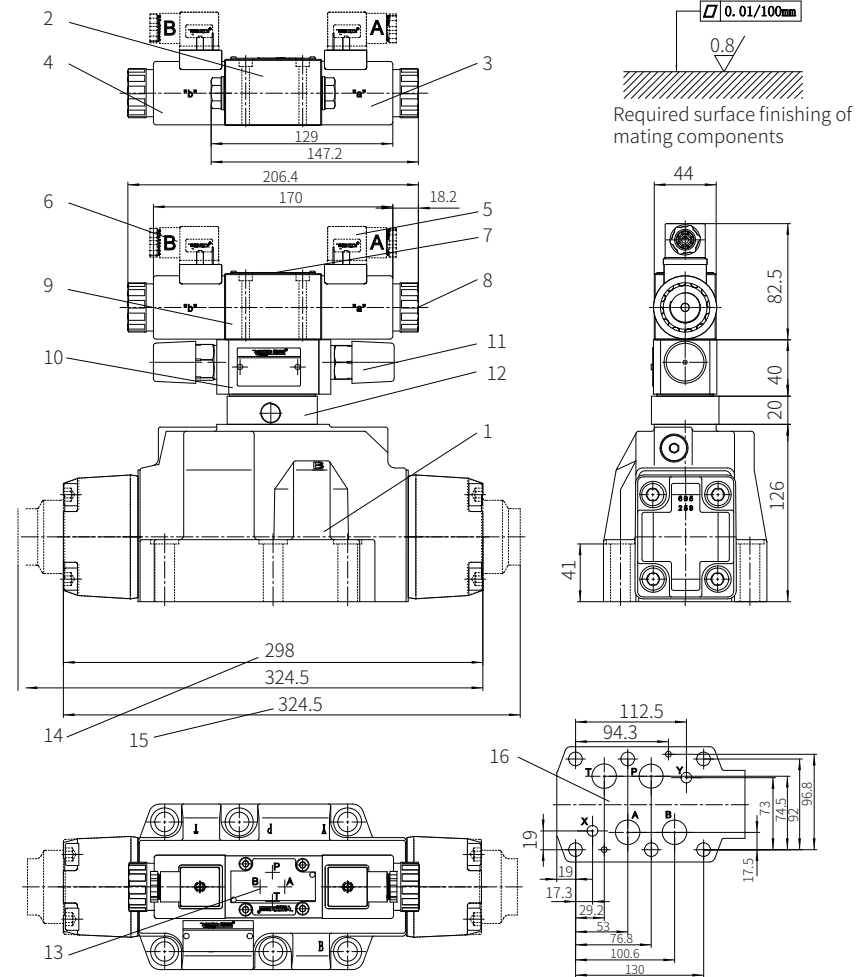

Required surface finishing of mating components

- | | | |
|--|---|---|
| 1 Main valve | 7 Name plate of pilot valve | 13 Port layout of main valve (valve mounting surface) |
| 2 2-position valve with one solenoid and plug Z4 | 8 Manual emergency operation | 14 Size of 3-position valve with spring centered |
| 3 Solenoid a | 9 2-position or 3-position valve with two solenoids and plug Z4 | 15 Size of 2-position valve with spring centered |
| 4 Solenoid b | 10 Switching time adjustment | 16 Main valve connection diagram |
| 5 Gray plug (or transparent plug) | 11 Adjustment bolt | |
| 6 Black plug (or transparent plug) | 12 Pressure reducing valve | |
- Valve fixing screw
6-M12x60-10.9 grade GB/T70.1-2000
Tightening torque $M_A=95Nm$

Component size

Size unit: mm

Dimension of additional devices for model WEH25

The installation range of the stroke adjustment is 12.5mm. The stroke limiter is used to adjust the stroke of the main spool. Loosen the lock nut and rotate the adjusting rod clockwise, the stroke of the main spool will be shortened (the adjustment must be carried out without pressure in the control chamber)

1 turn = 1.5mm stroke

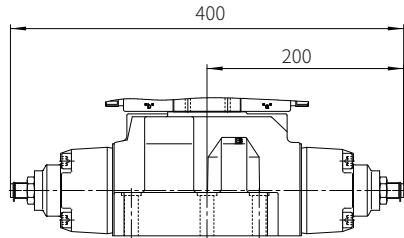
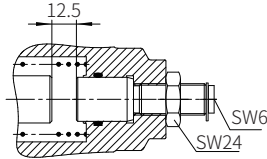

- Stroke adjustment installed on the ends A and B of the main valve.../10
- Stroke adjustment installed on the end A of the main valve.../11
- Stroke adjustment installed on the end B of the main valve.../12

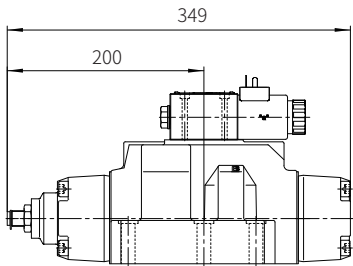

- Stroke adjustment installed on the end A of the main valve.../11 (2-position valve, symbols C, D, K, Z)

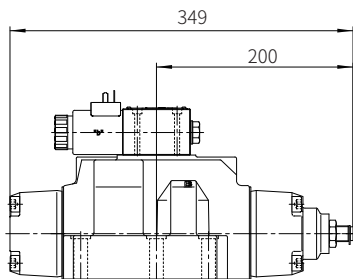

- Stroke adjustment installed on the end B of the main valve.../12 (2-position valve, symbol Y)

Component size

Size unit: mm

WEH32...5XJ/...

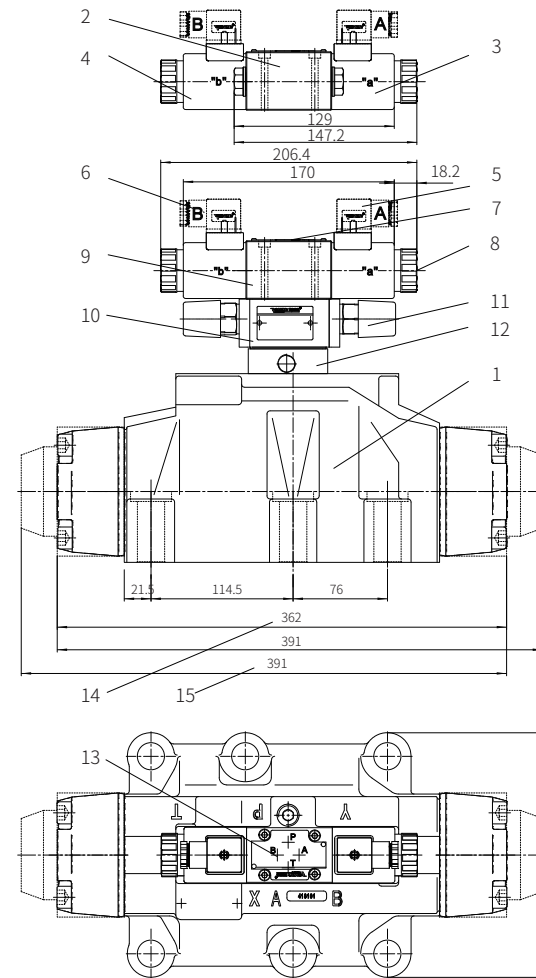

- 1 Main valve
- 2 2-position valve with one solenoid and plug Z4
- 3 Solenoid a
- 4 Solenoid b
- 5 Gray plug (or transparent plug)
- 6 Black plug (or transparent plug)
- 7 Name plate of pilot valve
- 8 Manual emergency operation
- 9 2-position or 3-position valve with two solenoids and plug Z4
- 10 Switching time adjustment
- 11 Adjustment bolt
- 12 Pressure reducing valve

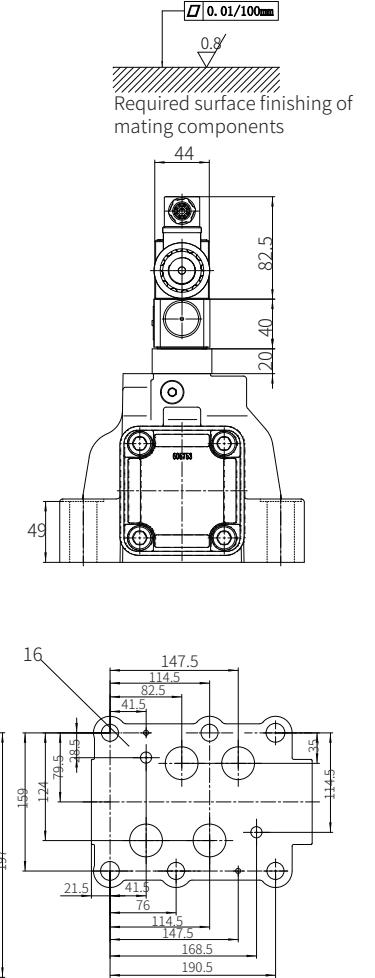

- 13 Port layout of main valve (valve mounting surface)
- 14 Size of 3-position valve with spring centered
- 15 Size of 2-position valve with spring centered
- 16 Main valve connection diagram

Valve fixing screw
6-M20x80-10.9 grade GB/T70.1-2000
Tightening torque $M_A=373Nm$

Component size

Size unit: mm

Dimension of additional devices for model WEH32

The installation range of the stroke adjustment is 15mm. The stroke limiter is used to adjust the stroke of the main spool. Loosen the lock nut and rotate the adjusting rod clockwise, the stroke of the main spool will be shortened (the adjustment must be carried out without pressure in the control chamber)

1 turn = 1.5mm stroke

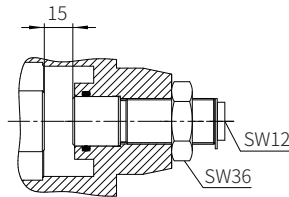

Stroke adjustment installed on the ends A and B of the main valve.../10

Stroke adjustment installed on the end A of the main valve.../11

Stroke adjustment installed on the end B of the main valve.../12

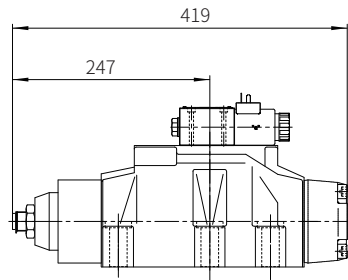
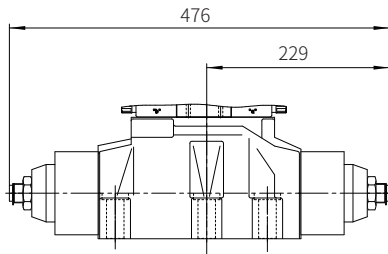
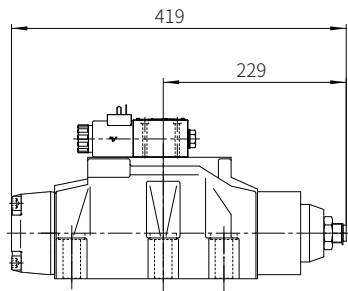
Stroke adjustment installed on the end A of the main valve.../11
(2-position valve, symbols C, D, K, Z)Stroke adjustment installed on the end B of the main valve.../12
(2-position valve, symbol Y)

Hydraulic or Electro-hydraulic Directional Valve

Model: WEH/WH...4X/6X/7XJ

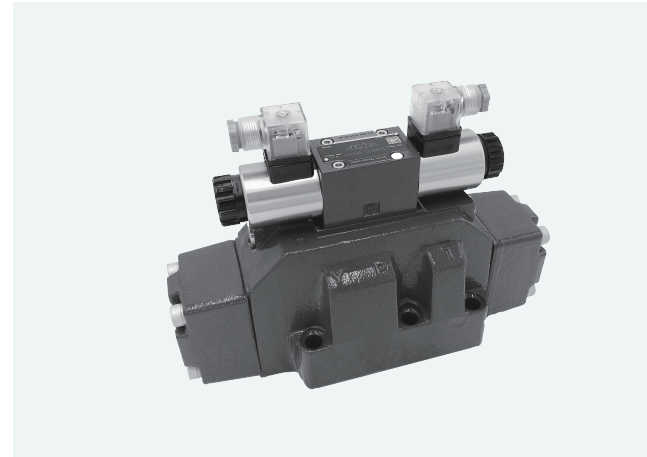

- ◆ Size 10~32
- ◆ Maximum working pressure 350 bar
- ◆ Maximum working flow 1100 L/min

Contents

Function description, sectional drawing	02 - 04
Models and specifications	05
Functional symbols	06-08
Technical parameters	09-10
Characteristic curve	11-15
Characteristic limit	11-15
Switching time adjustment, pressure reducing valve and pre-load valve	16
Component size	17-25

Features

- Mainly used to control the opening, closing and direction of liquid flow
- Electro-hydraulic operation (WEH)
- Hydraulic operation (WH)
- Subplate mounting
- The mounting surface according to DIN24340 form A and ISO4401
- Spring or hydraulic centered
- Spring or hydraulic return to initial position
- Wet-pin DC or AC solenoid
- Optional manual emergency operation
- Individual or central electrical connection
- Optional switching time adjustment
- Optional pre-load valve in port P of the main valve
- Auxiliary component, optional
- Stroke adjustment of main spool
- Stroke adjustment or end position sensor
- Inductive or mechanical limit switch (proximity type) of the main spool