

## 2-way Logic Cartridge Valves Directional Function

Model: LC...7XJ(logic cartridge valves)  
LFA...7XJ(control cover)

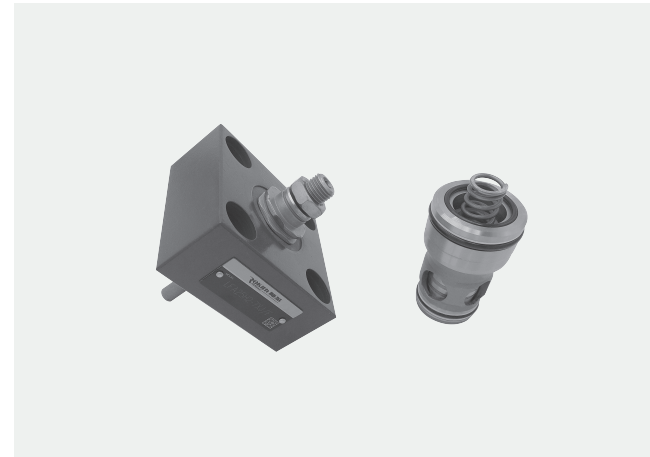

- ◆ Size 16/63
- ◆ Maximum working pressure 420 bar
- ◆ Maximum working flow 3000 L/min

### Contents

Function description, sectional drawing	02
Component size	03
Logic cartridge valves models and specifications	04
Technical parameters	04-05
Characteristic curve	06
Characteristic curve for throttle selection	07
Ordering code for throttle	07
Valve fixing screw	08
Control cover "D"	09
Control cover "H."	10-11
Control cover "G"	12
Control cover "R" and "RF"	13
Control cover "WEA" and "WEB"	14-15
Control cover "WEMA" and "WEMB"	16-17
Control cover "WECA"	18-19
Control cover "GWA" and "GWB"	20-21
Control cover "KWA" and "KWB"	22-24

### Features

- Valve poppet with or without damping nose
- 2 area ratios
- 4 types of springs
- 4 stroke limitations
- Control cover with integrated seat valve
- Control cover with integrated shuttle valve
- Control cover for set-up of directional spool valves with or without installed shuttle valve
- Control cover for set-up of directional seat valves with or without installed shuttle valve

Any part of this brochure can not be reproduced, edited, copied and disseminated electronically in any way without authorization of Jiayite Hydraulics company. As the product is in constant development and innovation, the information in this brochure is not specific to the special conditions or applicability of a specific industry, thus Jiayite Hydraulics company is not responsible for any incomplete or inaccurate description generated.



## Function description, sectional drawing

The 2-way logic cartridge valves are designed as components for integrated blocks. The main valve component with oil ports A and B is installed into the control block in a receiving hole standardized according to DIN ISO 7368 and closed with a cover. In most cases, the control cover is the connection between the control side of the main valve component and the pilot valve.

By control with respective pilot control valves, the main valve component can be applied for pressure, directional and throttle functions or a combination of these functions. The special economical structural designs can be achieved by matching the size of various flows of the valves and the actuators. If the main valve component can undertake more than one function, the special economical structure can be achieved.

### Directional function

The 2-way logic cartridge valves generally consist of control cover (1) and cartridge element (2). The control cover contains control holes, optional stroke limitation according to function, hydraulic control directional seat valve or shuttle valve. In addition, the directional spool valve or directional seat valve can be installed onto the control cover. The cartridge element mainly includes valve sleeve (3), adjustment ring (4) (only applicable to size 32), seat valve (5), optional damping (7) and reset spring (8).

### Function

The function of 2-way logic cartridge valves depends on the pressure. Therefore, there are three important pressure-bearing areas A1, A2, A3 for actuation of the valve. The area of the valve seat A1 is taken as 100%. Depending on the type, the annulus area A2 is 7% or 50% of the area A1. Therefore, the area ratio A1:A2 is either 14.3:1 or 2:1. The area A3 is equal to A1+A2. Due to the different area ratios A1:A2, the annulus area A2 is also different. The area A3 may be 107% or 150% when 100% area at seat A1.

### Basic application

The areas A1 and A2 are operated in the opening direction. The area A3 and the spring are operated in the closing direction. The effective direction generated by the combination of the opening and closing directions determines the position of the spool of the 2-way logic cartridge valve.

The oil can flow from A to B or B to A through the 2-way logic cartridge valve. When the area A3 is compressed by the pilot oil of channel B or external pilot oil supply, the channel A is closed without leakage."

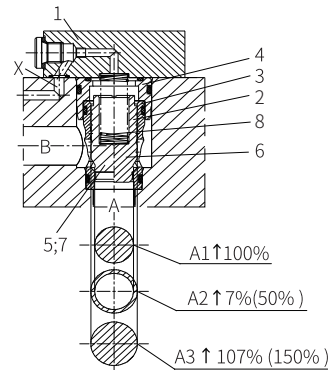
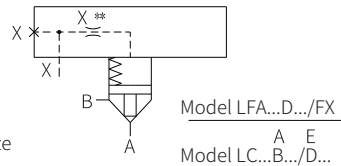

Size 16 to 32

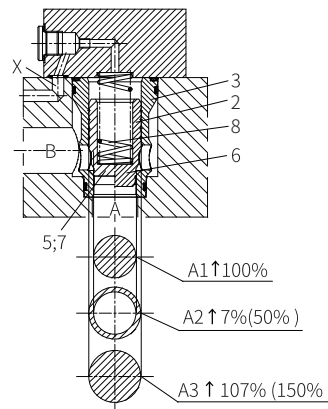

Size 40 to 63

## Component size

Size unit: mm

Control cover and installation hole according to ISO 7368

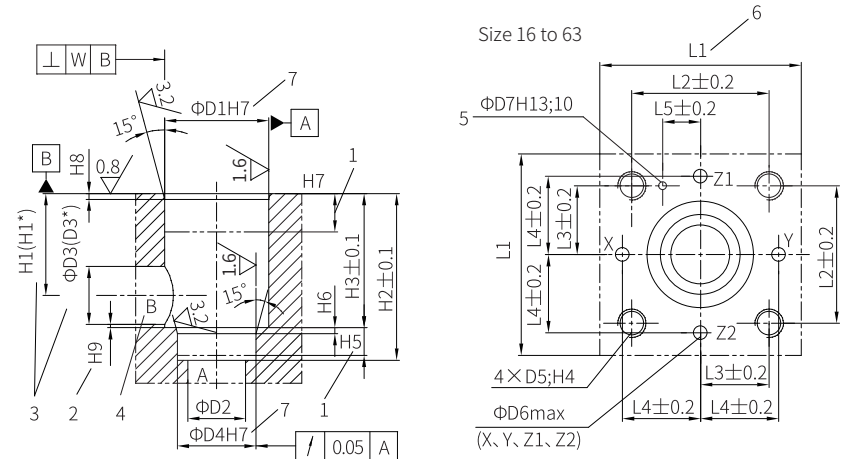

1 Depth of fit

2 Reference dimension

3 If the diameter of port B is not  $\Phi D3$  or  $(\Phi D3^*)$ , then the distance from the cover support surface to the center of the hole must be calculated.

4 Port B can be installed around the central axis of port A, but it must be ensured that the installation hole and pilot hole are not damaged

5 Locating pin hole

6 The length L1 (x-y axis of the hole) of the control cover (with directional valve) is 80mm for size 16.

7 If  $D \leq 45\text{mm}$ , H8 is allowed to be installed.

Size	16	25	32	40	50	63
$\Phi D1$	32	45	60	75	90	120
$\Phi D2$	16	25	32	40	50	63
$\Phi D3$	16	25	32	40	50	63
$\Phi D4$	25	34	45	55	68	90
$\Phi D5$	M8	M12	M16	M20	M20	M30
$\Phi D6$	4	6	8	10	10	12
$\Phi D7$	4	6	6	6	8	8
H1	34	44	52	64	72	95
(H1*)	29.5	40.5	48	59	65.5	96.5
H2	56	72	85	105	122	155
H3	43	58	70	87	100	130
H4	20	25	35	45	45	65
H5	11	12	13	15	17	20
H6	2	2.5	2.5	3	3	4
H7	20	30	30	30	35	40
H8	2	2.5	2.5	3	4	4
H9	0.5	1	1.5	2.5	2.5	3
L1	65/80	85	102	125	140	180
L2	46	58	70	85	100	125
L3	23	29	35	42.5	50	62.5
L4	25	33	41	50	58	75
L5	10.5	16	17	23	30	38
W	0.05	0.05	0.1	0.1	0.1	0.2



Characteristic curve

(Measured when using HLP46,  $\vartheta_{oil} = 40^{\circ}\text{C} \pm 5^{\circ}\text{C}$ )

Without damping nose

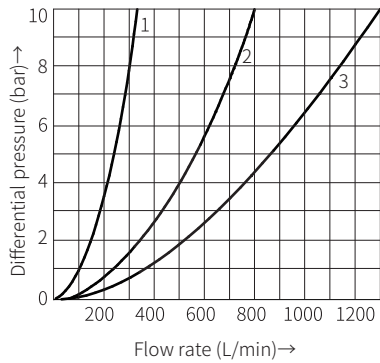

- 1 Size 16
- 2 Size 25
- 3 Size 32

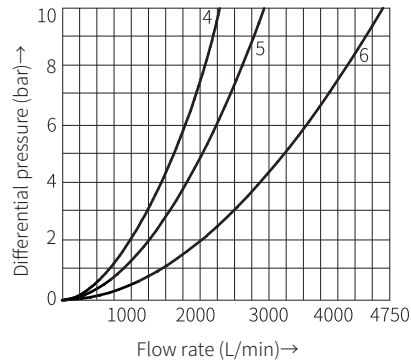

- 4 Size 40
- 5 Size 50
- 6 Size 63

With damping nose

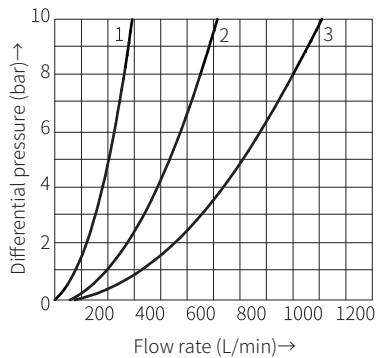

- 1 Size 16
- 2 Size 25
- 3 Size 32

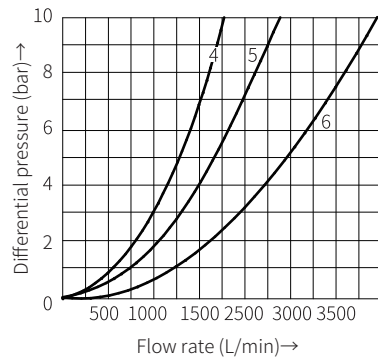

- 4 Size 40
- 5 Size 50
- 6 Size 63

Characteristic curve for throttle selection

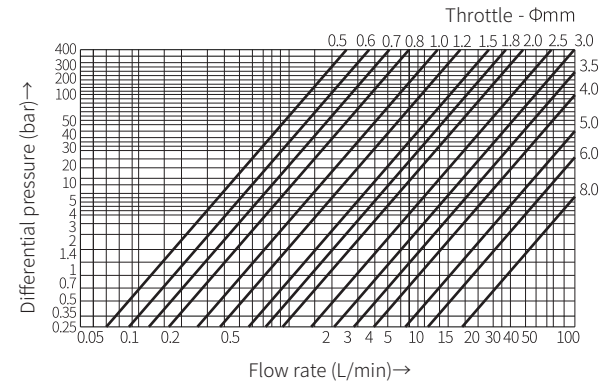

Thread	Throttle - $\Phi$ mm
ZM6	0.5 to 3.0
ZM8	0.5 to 4.0
R3/8	0.8 to 6.0
R1/2	1.0 to 8.0

Ordering code for throttle

Nominal size	Thread		Ordering code			
	Throttle $\Phi$ mm		ZM6	ZM8	R3/8	R3/8
	0.5		ZM6 $\times$ 1- $\Phi$ 0.5	ZM8 $\times$ 1- $\Phi$ 0.5	—	—
	0.6		ZM6 $\times$ 1- $\Phi$ 0.6	ZM8 $\times$ 1- $\Phi$ 0.6	—	—
	0.7		ZM6 $\times$ 1- $\Phi$ 0.7	ZM8 $\times$ 1- $\Phi$ 0.7	—	—
16	0.8		ZM6 $\times$ 1- $\Phi$ 0.8	ZM8 $\times$ 1- $\Phi$ 0.8	R3/8- $\Phi$ 0.8	—
25	1		ZM6 $\times$ 1- $\Phi$ 1.0	ZM8 $\times$ 1- $\Phi$ 1.0	R3/8- $\Phi$ 1.0	R1/2- $\Phi$ 1.0
32	1.2		ZM6 $\times$ 1- $\Phi$ 1.2	ZM8 $\times$ 1- $\Phi$ 1.2	R3/8- $\Phi$ 1.2	R1/2- $\Phi$ 1.2
40	1.5		ZM6 $\times$ 1- $\Phi$ 1.5	ZM8 $\times$ 1- $\Phi$ 1.5	R3/8- $\Phi$ 1.5	R1/2- $\Phi$ 1.5
50	1.8		ZM6 $\times$ 1- $\Phi$ 1.8	ZM8 $\times$ 1- $\Phi$ 1.8	R3/8- $\Phi$ 1.8	R1/2- $\Phi$ 1.8
63	2		ZM6 $\times$ 1- $\Phi$ 2.0	ZM8 $\times$ 1- $\Phi$ 2.0	R3/8- $\Phi$ 2.0	R1/2- $\Phi$ 2.0
	2.5		ZM6 $\times$ 1- $\Phi$ 2.5	ZM8 $\times$ 1- $\Phi$ 2.5	R3/8- $\Phi$ 2.5	R1/2- $\Phi$ 2.5
	3		ZM6 $\times$ 1- $\Phi$ 3.0	ZM8 $\times$ 1- $\Phi$ 3.0	R3/8- $\Phi$ 3.0	R1/2- $\Phi$ 3.0
	3.5		—	ZM8 $\times$ 1- $\Phi$ 3.5	R3/8- $\Phi$ 3.5	R1/2- $\Phi$ 3.5
	4		—	ZM8 $\times$ 1- $\Phi$ 4.0	R3/8- $\Phi$ 4.0	R1/2- $\Phi$ 4.0
	5		—	—	R3/8- $\Phi$ 5.0	R1/2- $\Phi$ 5.0
	6		—	—	R3/8- $\Phi$ 6.0	R1/2- $\Phi$ 6.0
	8		—	—	—	R1/2- $\Phi$ 8.0

Valve fixing screw

Infernal hexagon according to GB/T70.1-10.9 grade (included in the supply list)

Size	Control cover type	Dimension	Quantity	Tightening torque M <sub>v</sub> (N·m)	Size	Control cover type	Dimension	Quantity	Tightening torque M <sub>v</sub> (N·m)
16	D	M8×40	4	34.3	40	D	M20×70	4	373
	G	M8×40				G	M20×70		
	GW A, GW B	M8×45				GW A, GW B	M20×70		
	H1, H2	M8×40				H1, H2	M20×110		
						R, RF	M20×70		
	KW A, KW B	M8×45				KW A, KW B	M20×70		
	W E A, WEB	M8×45				W E A, WEB	M20×70		
	W ECA	M8×40				W ECA	M20×70		
WEMA, WEM B	M8×70	WEMA, WEM B	M20×70						
25	D	M12×50	4	95	50	D	M20×80	4	373
	G	M12×50				G	M20×80		
	GW A, GW B	M12×50				GW A, GW B	M20×80		
	H1, H2	M12×50				H2	M20×120		
	R, RF	M12×50				R, RF	M20×80		
	KW A, KW B	M12×50				KW A, KW B	M20×80		
	WEA, WEB	M12×50				WEA, WEB	M20×80		
	W ECA	M12×50				W EC A	M20×80		
WEMA, WEM B	M12×50	WEMA, WEM B	M20×80						
32	D, G, R, RF GW A, GW B, KW A, KW B, W EA, W EB, W ECA, W EMA, W EMB	M16×60	4	196	63	D, G, R, RF GW A, GW B, KW A, KW B, W EA, W EB, W ECA, W EMA, W EMB	M30×100	4	1315
	H1, H2	M16×80				H2	M30×150		

Control cover "D" with remote control

Size 16 to 63

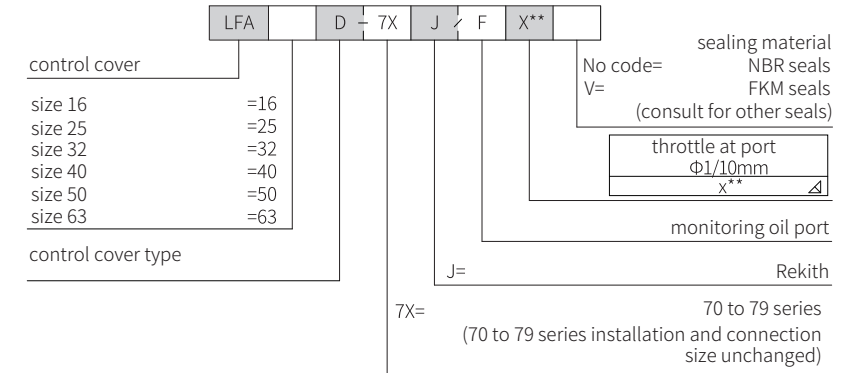

If necessary, please provide specifications of the throttle  
e.g. X12= throttle Φ 1.2mm  
Standard throttle see page 07/24

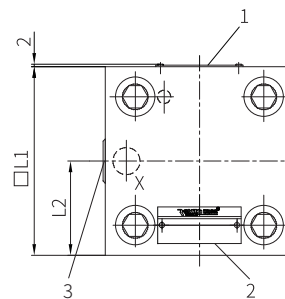
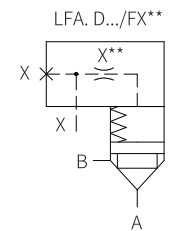
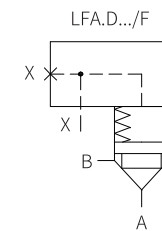
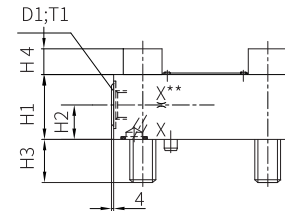

Size	16	25	32	40	50	63
D1	G1/8	G1/4	G1/4	G1/2	G1/2	G3/4
X** <sup>1)</sup>	ZM6	ZM6	ZM6	ZM8	ZM8	R3/8
H1	27	30	35	60	68	82
H2	12	16	16	30	32	40
H3	15	20	25	32	34	50
H4	6	12	16	—	—	—
L1	65	85	100	125	140	180
L2	32.5	42.5	50	72	80	90
T1	8	12	12	14	14	16
Weight kg	0.9	1.7	2.7	6.6	9.4	18.7

<sup>1)</sup> Ordering code of throttle see page 07/24

- 1 Name plate for size 16/25/32
- 2 Name plate for size 40/50/63
- 3 Optional port X used as threaded connection port

Control cover "H" with stroke limitation and remote control

Size 16 to 40

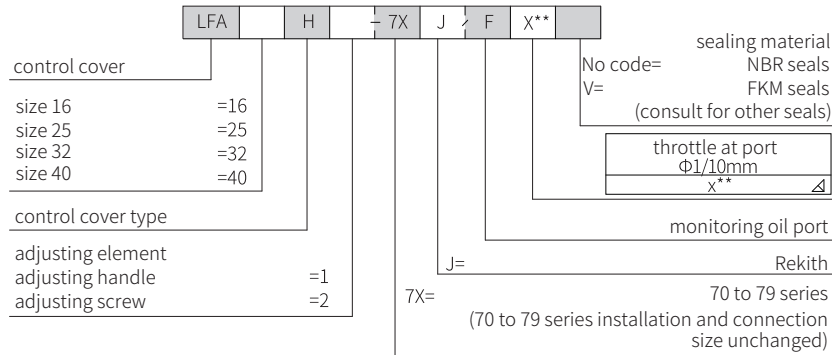

If necessary, please provide specifications of the throttle  
e.g. X12= throttle Φ 1.2mm  
Standard throttle see page 07/24

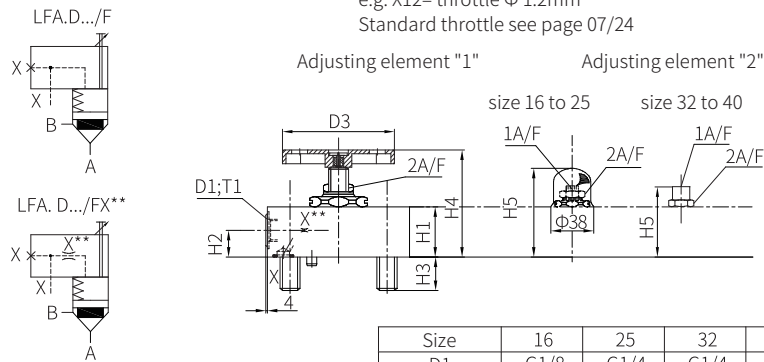

Size	16	25	32	40
D1	G1/8	G1/4	G1/4	G1/2
X** <sup>1)</sup>	ZM6	ZM6	ZM6	ZM8
D3	60	80	80	100
H1	35	40	75	95
H2	12	16	16	30
H3	15	24	28	32
H4max	90	95	120	160
H5max	76	80	100	146
□L1	65	85	100	125
L2	32.5	42.5	50	72
T1	8	12	12	14
1A/F <sup>2)</sup>	6	6	10	14
2A/F	21	22	27	46
Weight kg	1.3	2.3	5.5	11.2

- 1 Name plate for size 16/25/32
- 2 Name plate for size 40
- 3 Optional port X used as threaded connection port

<sup>1)</sup> Ordering code of throttle see page 07/24  
<sup>2)</sup> Internal hexagon

Control cover "H" with stroke limitation and remote control

Size 50 to 63

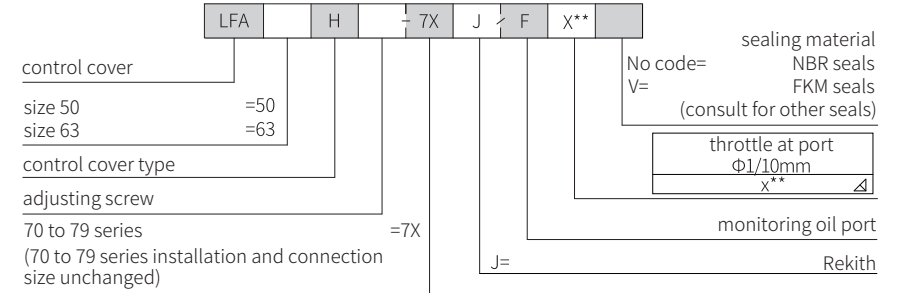

If necessary, please provide specifications of the throttle  
e.g. X12= throttle Φ 1.2mm  
Standard throttle see page 07/24

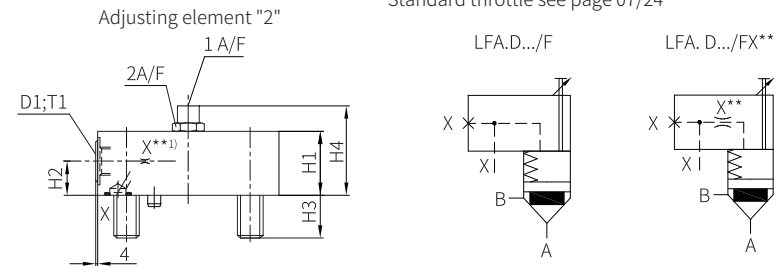

Size	50	63
D1	G1/2	G3/4
X** <sup>1)</sup>	ZM8	R3/8
H1	110	125
H2	32	40
H3	34	50
H4max	156	175
□L1	140	180
L2	80	90
T1	14	16
1A/F <sup>2)</sup>	17	24
2A/F	55	65
Weight kg	15.8	30.2

<sup>1)</sup> Ordering code of throttle see page 07/24  
<sup>2)</sup> Internal hexagon

- 1 Name plate
- 2 Optional port X used as threaded connection port

Control cover "G" with integrated shuttle valve

Size 16 to 63

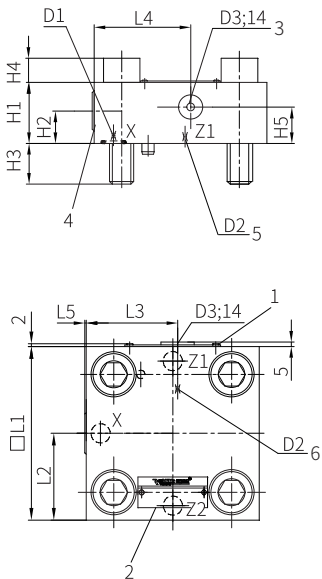
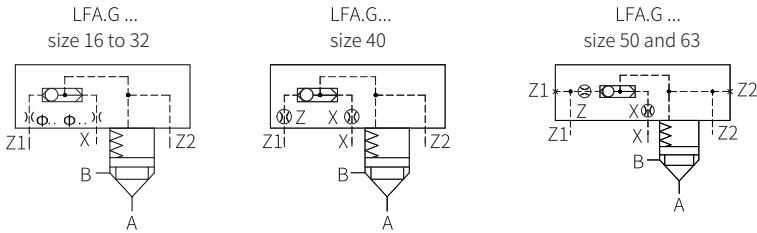
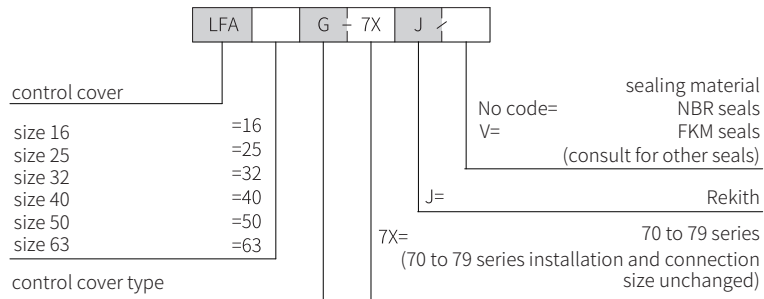

Size	16	25	32	40	50	63
D1 <sup>2)</sup>	Φ1.2	Φ1.5	Φ2.0	M6	M8×1	M8×1
D2 <sup>2)</sup>	Φ1.2	Φ1.5	Φ2.0	M6	M8×1	M8×1
D3	—	—	—	—	G1/2	G1/2
H1	35	30	35	60	68	82
H2	17	17	21.5	30	32	42
H3	15	24	28	32	34	50
H4	—	12	16	—	—	—
H5	—	—	—	—	32	40
L1	65	85	100	125	140	180
L2	36.5	45.5	50	62.5	70	90
L3	—	—	—	—	72	81
L4	—	—	—	—	72	90
L5	4.5	4	1	—	6	4

- 1 Name plate for size 16/25/32
- 2 Name plate for size 40/50/63
- 3 Optional ports Z1 and Z2 used as threaded connection ports for size 25/32/50/63
- 4 Shuttle valve
- 5 D2 for size 16 to 40

Control cover "R" and "RF" with integrated directional seat valve

Size 25 to 63

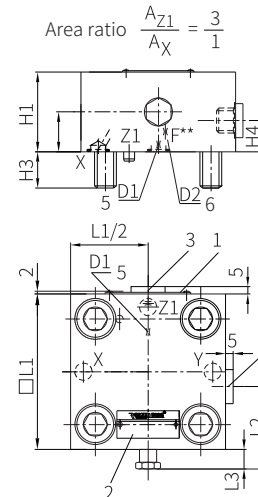
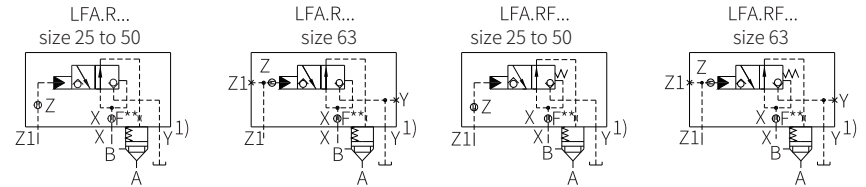
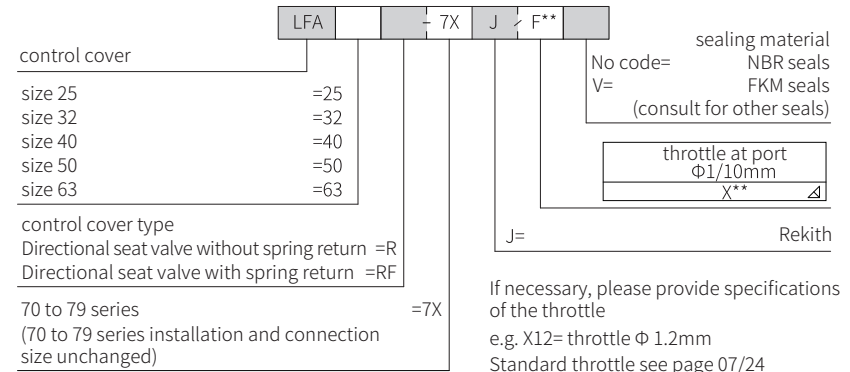

Size	Type	25	32	40	50	63
F** <sup>2)</sup>		ZM6	ZM6	ZM8	ZM8	ZM8
H1		40	50	60	68	82
H2		20	26	30	34	40
H3		24	28	32	34	50
H4		15.5	26	30	34	40
□L1		85	100	125	140	180
L2		50	50	65.7	70	78.5
L3	R	3	3	4	4	—
	RF	18	18	25	25	16
Weight kg		2.1	3.6	6.7	9.5	18.3

- <sup>1)</sup> Maximum working pressure at port Y 5 bar
- <sup>2)</sup> Ordering code of throttle see page 07/24

- 1 Name plate for size 16/25/32
- 2 Name plate for size 40/50/63
- 3 Optional port Z1 used as threaded connection port for size 25 to 63
- 4 Optional port Z1 used as threaded connection port for size 25 to 63
- 5 D1 for size 25 to 50
- 6 D1 for size 63

Control cover "WEA" and "WEB" for set-up of a directional spool or directional seat valve

Size 16 to 50

LFA [ ] [ ] - 7X [ ] / A\*\* B\*\* P\*\* T\*\* [ ]

control cover [ ]  
size 16 =16  
size 25 =25  
size 32 =32  
size 40 =40  
size 50 =50

control cover type  
normally closed =WEA  
normally open =WEB

No code= NBR seals  
V= FKM seals  
(consult for other seals)

control type	throttle at port $\Phi 1/10\text{mm}$		
WEA	A**	P**	T**
WEB	B**	P**	T**

J= [ ]      Rekith  
7X= [ ]      70 to 79 series  
(70 to 79 series installation and connection size unchanged)

▲ If necessary, please provide specifications of the throttle  
e.g. X12= throttle  $\Phi 1.2\text{mm}$   
Standard throttle see page 07/24

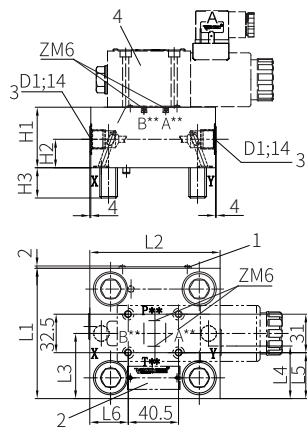
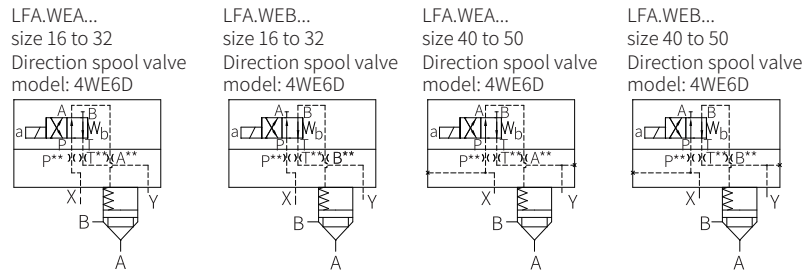

Size	16	25	32	40	50
D1	—	—	—	G1/2	G1/2
H1	40	40	50	60	68
H2	—	—	—	30	32
H3	15	24	28	32	34
L1	65	85	100	125	140
L2	80	85	100	125	140
L3	—	—	—	72	80
L4	—	—	—	53	60
L5	17	27	34.5	47	54.5
L6	7	23.5	31	43.5	51
A**B** T**,P** <sup>1)</sup>	ZM6	ZM6	ZM6	ZM6	ZM6
Weight kg	1.5	2.1	3.6	6.6	9.3

- <sup>1)</sup> Ordering code of throttle see page 07/24  
 1 Name plate for size 16/25/32  
 2 Nameplate for size 40/50  
 3 Optional ports X and Y used as threaded connection ports for size 40/50  
 4 Direction spool valve 4WE6D and screw M5x50-10.9 GB T70.1 must be ordered separately

Control cover "WEA" and "WEB" for set-up of a directional spool or directional seat valve

Size 63

LFA 63 [ ] - 7X J / A\*\* B\*\* P\*\* T\*\* [ ]

control cover [ ]  
size [ ]  
control cover type  
normally closed =WEA  
normally open =WEB

No code= NBR seals  
V= FKM seals  
(consult for other seals)

control type	throttle at port $\Phi 1/10\text{mm}$		
WEA	A**	P**	T**
WEB	B**	P**	T**

J= [ ]      Rekith  
7X= [ ]      70 to 79 series  
(70 to 79 series installation and connection size unchanged)

▲ If necessary, please provide specifications of the throttle  
e.g. X12= throttle  $\Phi 1.2\text{mm}$   
Standard throttle see page 07/24

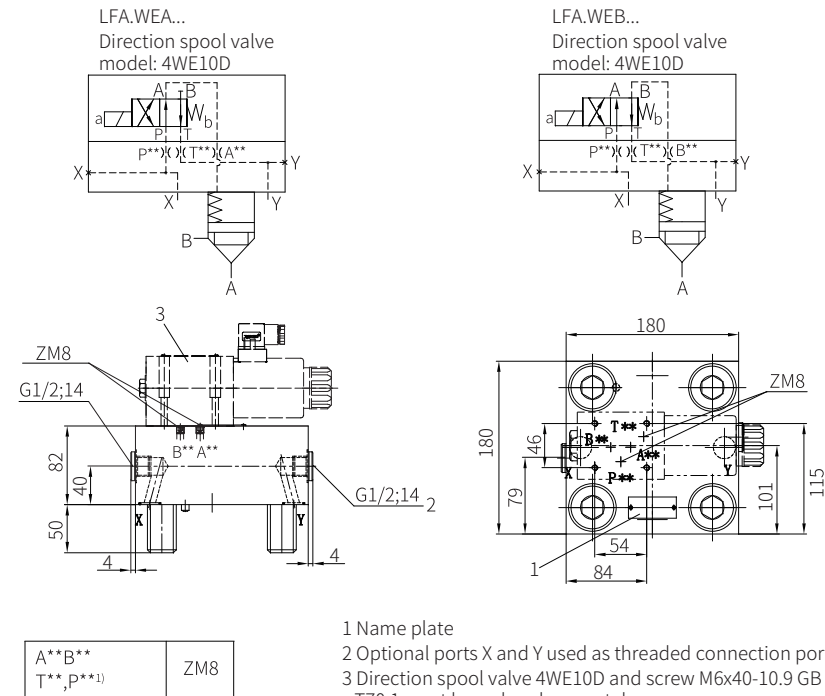

- 1 Name plate  
 2 Optional ports X and Y used as threaded connection ports  
 3 Direction spool valve 4WE10D and screw M6x40-10.9 GB T70.1 must be ordered separately  
 Weight (kg): 18.6

<sup>1)</sup> Ordering code of throttle see page 07/24

Control cover "WEMA" and "WEMB" for set-up of a directional spool or directional seat valve

Size 16 to 50

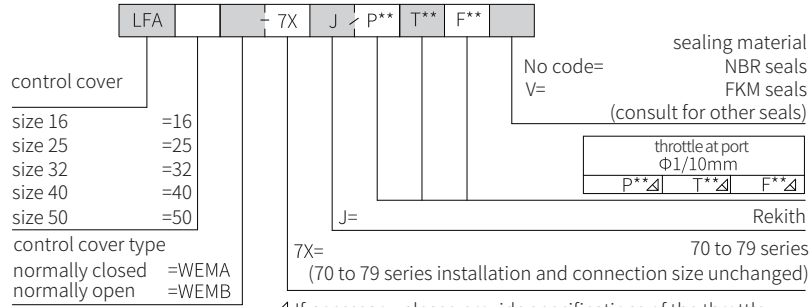

Δ If necessary, please provide specifications of the throttle e.g. X12= throttle  $\Phi 1.2\text{mm}$  Standard throttle see page 07/24

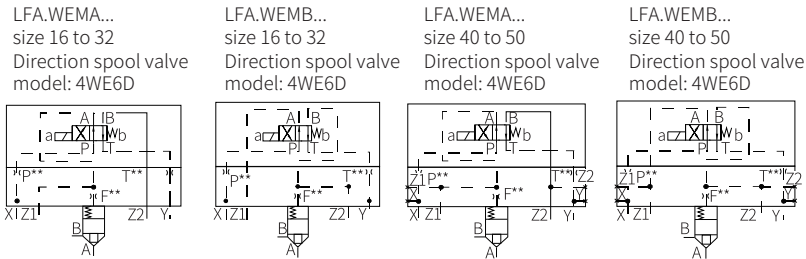

Size	16	25	32	40	50
D1	—	—	—	G1/2	G1/2
H1	65	40	50	60	68
H2	—	—	—	30	32
H3	15	24	28	32	34
L1	65	85	100	125	140
L2	80	85	100	125	140
L3	—	—	—	53	60
L4	17	27	34.5	47	54.5
L5	7	23.5	31	43.5	51
L6	—	—	—	72	80
P** T** F** <sup>1)</sup>	ZM6	ZM6	ZM6	ZM6	ZM6
F**	2.3	2.1	3.6	6.6	9.3

<sup>1)</sup> Ordering code of throttle see page 07/24

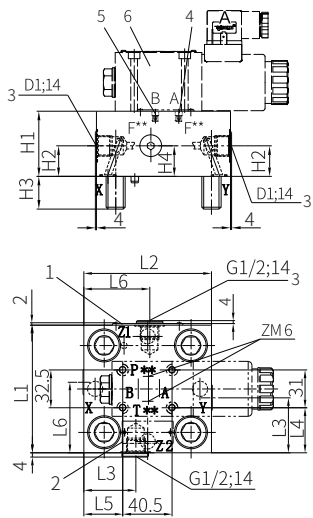

- 1 Name plate for size 16/25/32
- 2 Name plate for size 40/50
- 3 2 Optional ports X and Y used as threaded connection ports for size 40/50
- 4 Plug ZM6 for model: ..WEMB... (port B with or without throttle F \*\*, port A with plug)
- 5 Plug ZM6 for model: ..WEMA... (port A with or without throttle F \*\*, port B with plug)
- 6 Direction spool valve 4WE6D and screw M5x50-10.9 GB T70.1 must be ordered separately

Control cover "WEMA" and "WEMB" for set-up of a directional spool or directional seat valve

Size 63

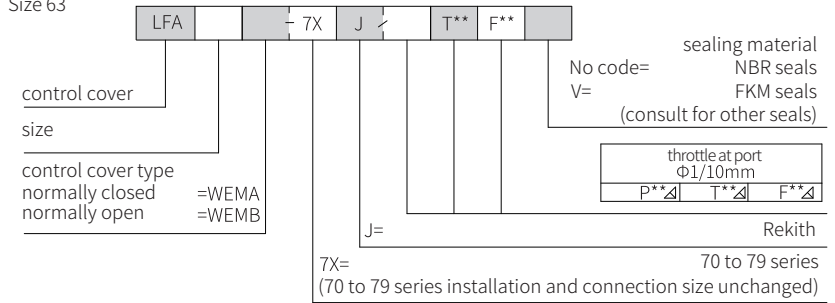

Δ If necessary, please provide specifications of the throttle e.g. X12= throttle  $\Phi 1.2\text{mm}$  Standard throttle see page 07/24

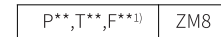
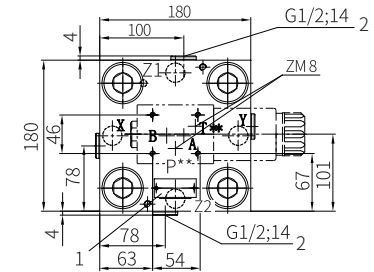
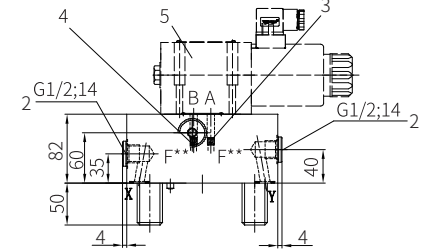
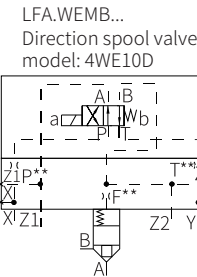
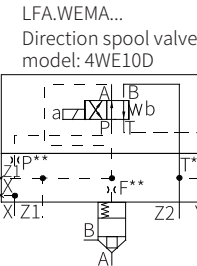

<sup>1)</sup> Ordering code of throttle see page 07/24

- 1 Name plate
- 2 Optional ports X/Y/Z1/Z2 used as threaded connection ports
- 3 Plug ZM8 for model: ..WEMB... (port B with or without throttle F \*\*, port A with plug)
- 4 Plug ZM8 for model: ..WEMA... (port A with or without throttle F \*\*, port B with plug)
- 5 Direction spool valve 4WE10D and screw M6x40-10.9 GB T70.1 must be ordered separately Weight (kg): 18.6

Control cover "WECA" for set-up of a directional spool valve

Size 16 to 50

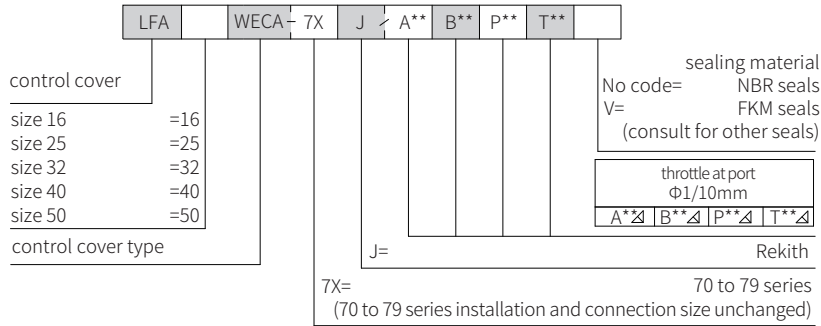

$\Delta$ If necessary, please provide specifications of the throttle  
e.g. X12= throttle  $\Phi 1.2\text{mm}$   
Standard throttle see page 07/24

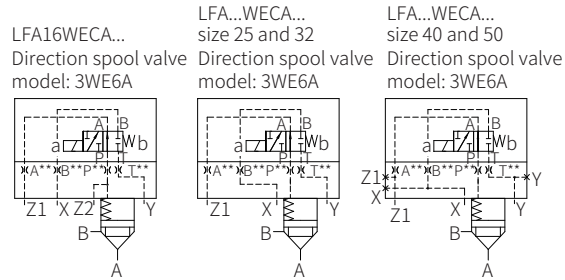
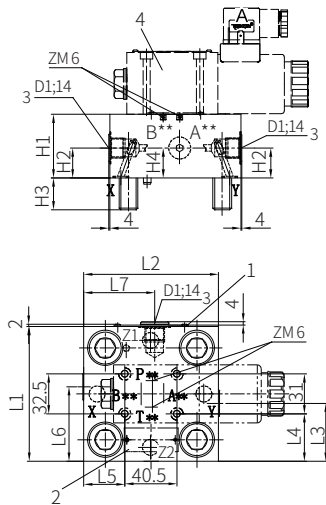

Size	16	25	32	40	50
D1	—	—	—	G1/2	G1/2
H1	40	40	50	60	68
H2	—	—	—	30	32
H3	15	24	28	32	34
H4	—	—	—	30	32
L1	65	85	100	125	140
L2	80	85	100	125	140
L3	—	—	—	53	60
L4	17	27	34.5	47	54.5
L5	7	23.5	31	43.5	51
L6	—	—	—	62.5	70
L7	—	—	—	72	80
A**B** P**T**1)	ZM 6	ZM 6	ZM 6	ZM 6	ZM 6
Weight kg	1.5	2.1	3.6	6.6	9.3

<sup>1)</sup> Ordering code of throttle see page 07/24

- 1 Name plate for size 16/25/32
- 2 Name plate for size 40/50
- 3 Optional ports X/Y/Z1 used as threaded connection ports for size 40 and 50
- 4 Direction spool valve 3WE6A and screw M5x50-10.9 GB T70.1 must be ordered separately

Control cover "WECA" for set-up of a directional spool valve

Size 63

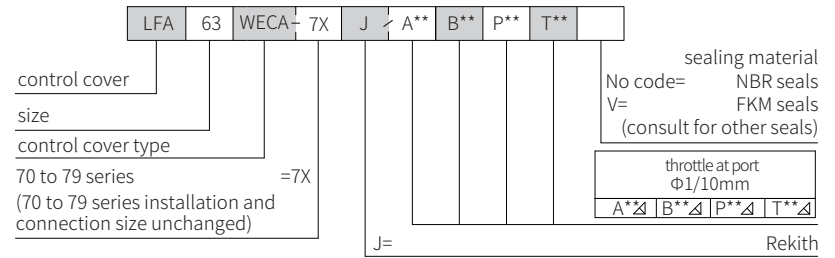

$\Delta$  If necessary, please provide specifications of the throttle  
e.g. X12= throttle  $\Phi 1.2\text{mm}$   
Standard throttle see page 07/24

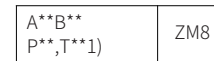
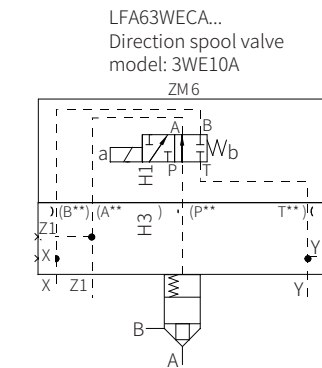

<sup>1)</sup> Ordering code of throttle see page 07/24

- 1 Name plate
- 2 Optional ports X/Y/Z1 used as threaded connection ports
- 3 Direction spool valve 3WE10A and screw M6x40-10.9 GB T70.1 must be ordered separately

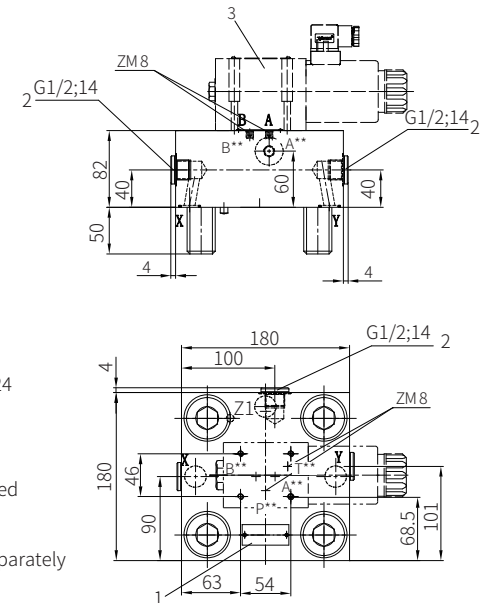

Control cover "GWA" and "GWB" for set-up of a directional spool or directional seat valve

Size 16 to 50

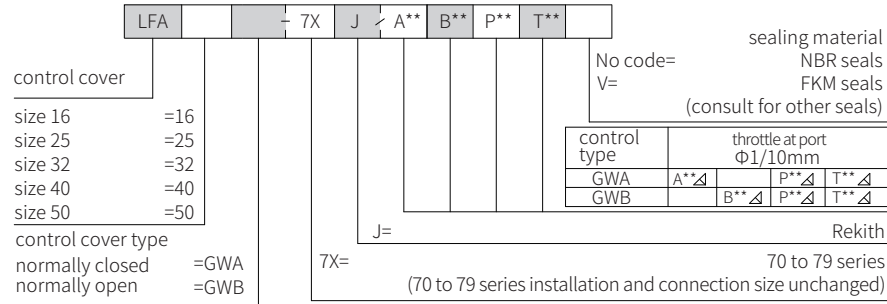

Δ If necessary, please provide specifications of the throttle  
e.g. X12= throttle Φ 1.2mm  
Standard throttle see page 07/24

LFA.GWA...  
size 16 to 32  
Direction spool valve  
model: 4WE6D

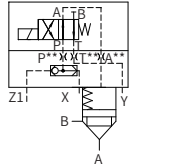

LFA.GWB...  
size 16 to 32  
Direction spool valve  
model: 4WE6D

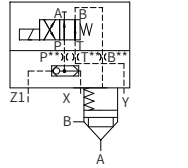

LFA.GWA...  
size 40 and 50  
Direction spool valve  
model: 4WE6D

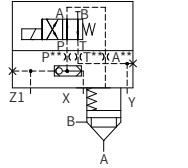

LFA.GWB...  
size 40 and 50  
Direction spool valve  
model: 4WE6D

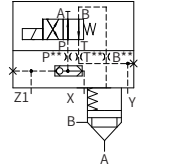

Size	16	25	32	40	50
D1	—	—	—	G1/2	G1/2
H1	40	40	50	60	68
H2	—	—	—	30	32
H3	15	24	28	32	34
H4	17	17	21.5	30	32
L1	65	85	100	125	140
L2	80	85	100	125	140
L3	36.5	45.5	50	62.5	72
L4	—	—	—	53	60
L5	—	—	—	62.5	70
L6	7	23.5	31	43.5	51
L7	17	27	34.5	47	54.5
A**B** P**T**1)	ZM 6	ZM 6	ZM 6	ZM 6	ZM 6
Weight kg	1.5	2.1	3.6	6.6	9.3

- Name plate for size 16/25/32
- Name plate for size 40/50
- Optional ports Y and Z1 used as threaded connection ports for size 40/50
- Shuttle valve
- Plug ZM6 for model: ..GWA...(port B with plug only)
- Plug ZM6 for model: ..GWB...(port A with plug only)
- Direction spool valve 4WE6D and screw M5x50-10.9 GB  
T70.1 must be ordered separately

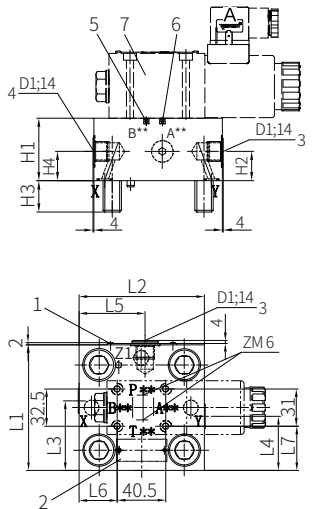

Control cover "GWA" and "GWB" for set-up of a directional spool or directional seat valve

Size 63

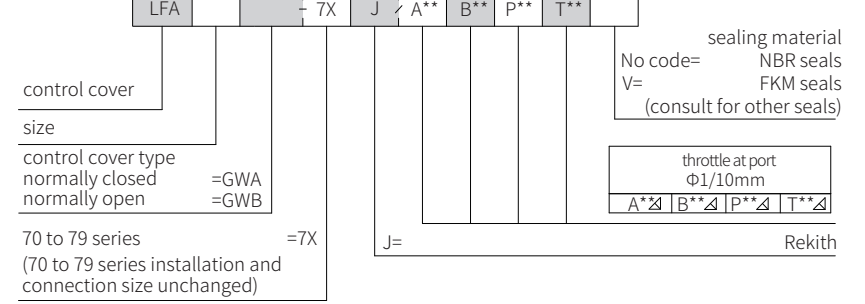

Δ If necessary, please provide specifications of the throttle  
e.g. X12= throttle Φ 1.2mm  
Standard throttle see page 07/24

LFA.63GWA...  
Direction spool valve  
model: 4WE10D

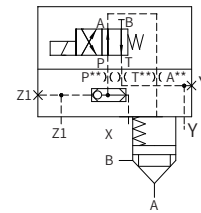

LFA.63GWB...  
Direction slide valve  
model: 4W E10D

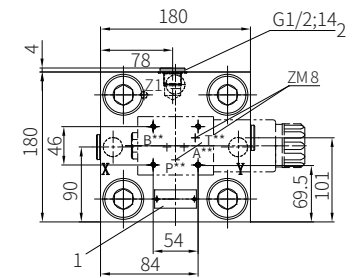
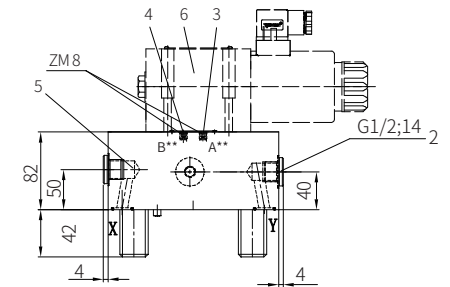
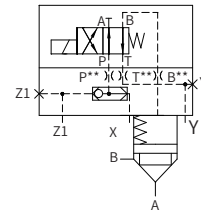

- Name plate
- Optional ports Y and Z1 used as threaded connection ports for size 40/50
- Plug ZM8 for model: ..GWB...(port A with plug only)
- Plug ZM8 for model: ..GWA...(port B with plug only)
- Shuttle valve
- Direction spool valve 4WE10D and screw M5x50-10.9 GB  
T70.1 must be ordered separately  
Weight (kg): 18.6

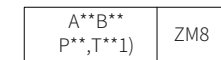

<sup>1)</sup> Ordering code of throttle see page 07/24

Control cover "KWA" and "KWB" for set-up of a directional spool or directional seat valve

Size 16 to 50

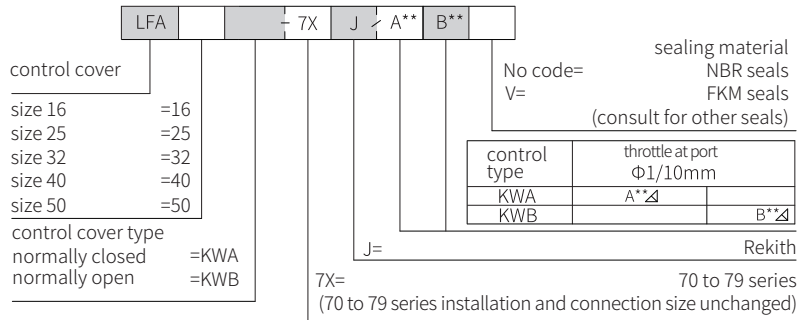

Δ If necessary, please provide specifications of the throttle  
e.g. X12= throttle Φ 1.2mm  
Standard throttle see page 07/24

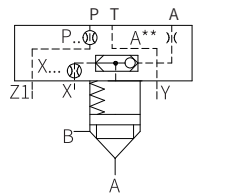
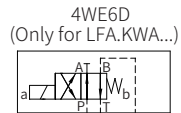
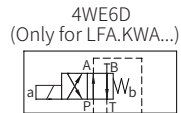

LFA16KWA...  
(see above model 4WE6D...)

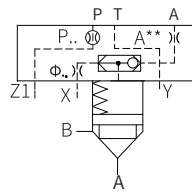

LFA.KWA...  
size 25 and 32  
(see above model 4WE6D...)

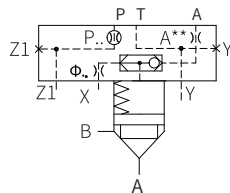

LFA.KWA...  
size 40 and 50  
(see above model 4WE6D...)

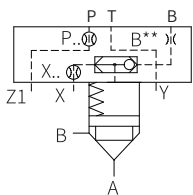

LFA16KWB...  
(see above model 4WE6D...)

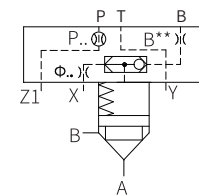

LFA.KWB...  
size 25 and 32  
(see above model 4WE6D...)

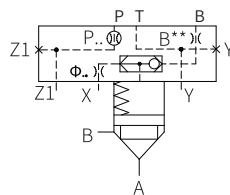

LFA.KWB...  
size 40 and 50  
(see above model 4WE6D...)

Control cover "KWA" and "KWB" for set-up of a directional spool or directional seat valve

Model ..KWA/..KWB..( size 16 to 50)

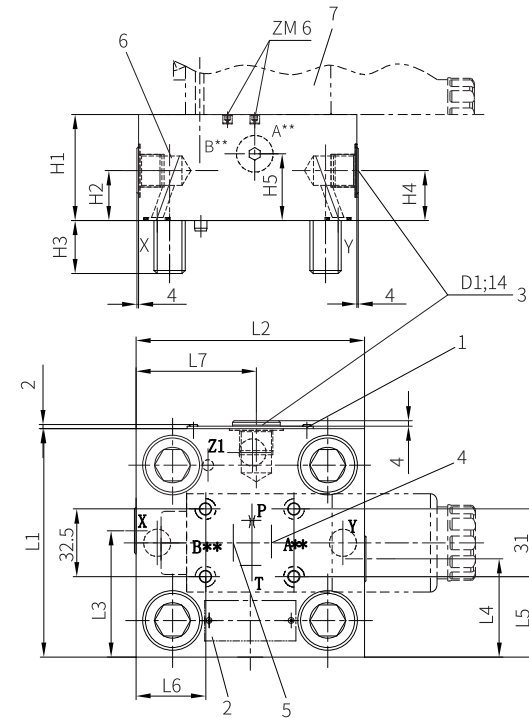

Size	16	25	32	40	50
D1	—	—	—	G1/2	G1/2
H1	40	40	50	60	68
H2	17	17	21.5	30	32
H3	15	24	28	32	34
H4	—	—	—	30	32
H5	—	—	—	30	50
L1	65	85	100	125	140
L2	80	85	100	125	140
L3	36.5	45.5	50	62.5	72
L4	—	—	—	53	60
L5	17	27	34.5	47	54.5
L6	7	23.5	31	43.5	51
L7	—	—	—	62.5	70
A**B** <sup>1)</sup>	ZM 6	ZM 6	ZM 6	ZM 6	ZM 6
Weight kg	1.5	2.1	3.6	6.6	9.3

- 1 Name plate for size 16/25/32
- 2 Name plate for size 40/50
- 3 optional ports Y and Z1 used as threaded connection ports for size 40/50
- 4 Plug ZM6 for model ..KWB...(port A with plug only)
- 5 Plug ZM6 for model ..KWA...(port B with plug only)
- 6 Shuttle valve
- 7 Direction spool valve 4WE6D and screw M5x50-10.9 GB T70.1 must be ordered separately

<sup>1)</sup>Ordering code of throttle see page 07/24

Control cover "KWA" and "KWB" for set-up of a directional spool or directional seat valve

Size 63

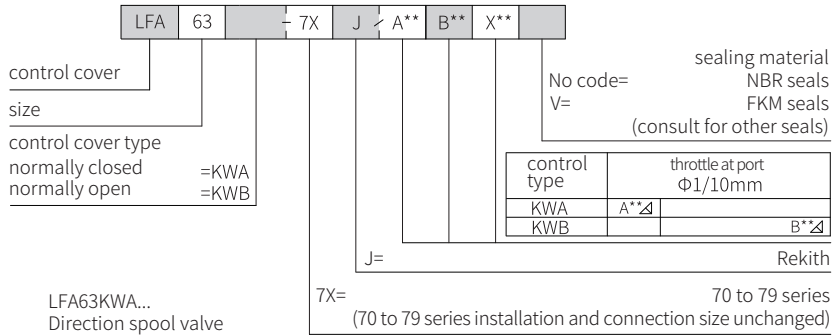

LFA63KWA...  
Direction spool valve  
model: 4WE10D

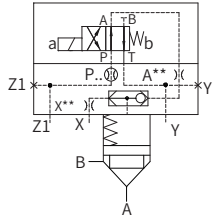

LFA63KWB...  
Direction spool valve  
model: 4WE10D

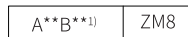
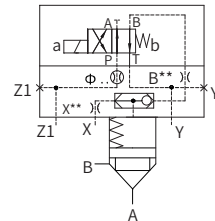

<sup>1)</sup>Ordering code of throttle see page 07/24

- 1 Name plate
- 2 Optional ports Y and Z1 used as threaded connection ports for size 40/50
- 3 Plug for model ..KWB...
- 4 Plug for model ..KWA...
- 5 Shuttle valve
- 6 Direction spool valve 4WE10D and screw M6x40-10.9 GB T70.1 must be ordered separately  
Weight (kg): 18.6

$\Delta$  If necessary, please provide specifications of the throttle  
e.g. X12= throttle  $\Phi$  1.2mm  
Standard throttle see page 07/24

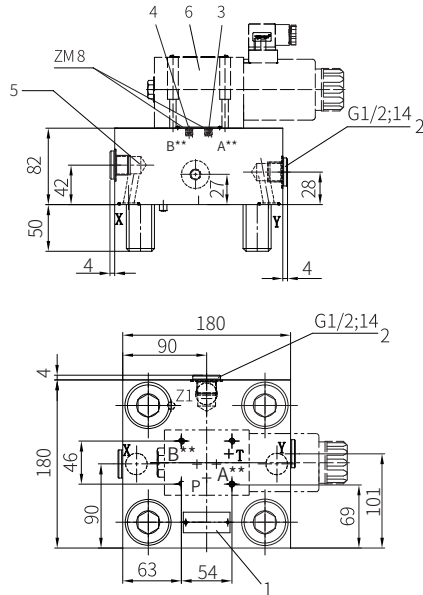

2-way Logic Cartridge Valves Pressure Function

Model: LC...7XJ(logic cartridge valves)  
LFA...7XJ(control cover)



- ◆ Size 16/63
- ◆ Maximum working pressure 420 bar
- ◆ Maximum working flow 2500 L/min

Contents

Function description, sectional drawing	02-03
Logic cartridge valves models and specifications	04
Technical parameters	05/08/09/27/31
Characteristic curve	05-08/27-30
Valve fixing screw	09
Control cover "DB"	09-11
Control cover "DBW" and "DBS"	12-15
Control cover "DBWD"	16-18
Control cover "DBU2A" and "DBU2B"	19-21
Control cover "DBU3D"	22-25
Logic cartridge valves models and specifications	26
Logic cartridge valves functional symbols	26
Application example	30
Valve fixing screw	31
Control cover component size	32
Control cover "DR"	33-34
Control cover "DRW"	35-36

Features

- Cartridge spool and various sleeves to meet relief and reducing function
- One sleeve with multi-spool in cartridge structure
- Area ratio 1:1 and 1.07:1
- Optional throttle
- Different cracking pressures