

## Component size

Size unit: mm

Model 2FRM5-3XJ/...

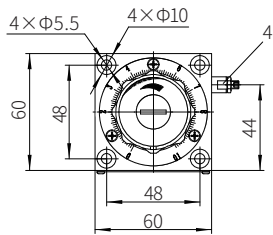
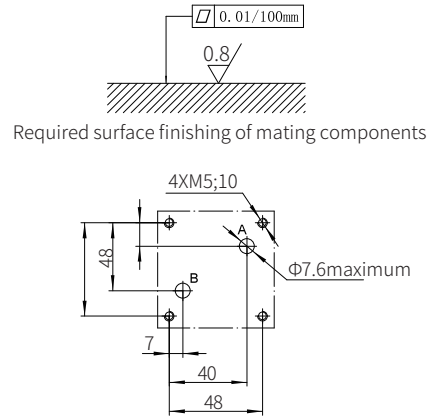
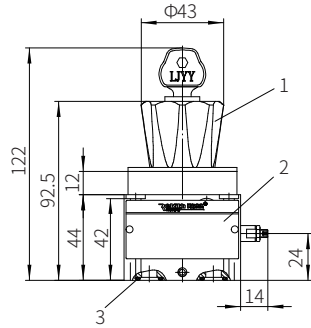

O ring 12x2 (for oil port A, B)  
 M5x50-10.9 stage GB/T70.1-2000  
 Tightening torque  $M_A=7.8\text{Nm}$   
 Subplate model:  
 G44/01(G1/4"); G44/02(M14x1.5)  
 G45/01(G1/2"); G45/02(M22x1.5)

## Component size

Size unit: mm

Model Z4S5-1XJ/...

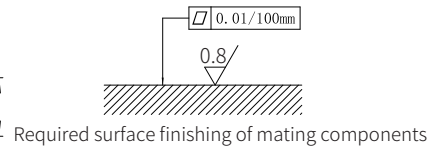
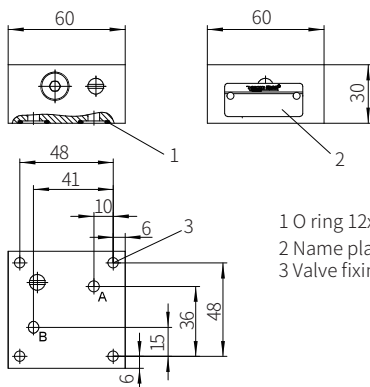

1 O ring 12x2 (for oil port A, B)  
 2 Name plate  
 3 Valve fixing screw hole

## Two Ways Flow Control Valve

Model: 2FRM6...3XJ



- ◆ Size 6
- ◆ Maximum working pressure 315 bar
- ◆ Maximum working flow 32 L/min

## Contents

Function description, sectional drawing	02-03
Functional symbols	03-04
Models and specifications	04
Technical parameters	05
Characteristic curve	06
Component size	07-08

## Features

- Optional pressure compensator closed externally
- Subplate mounting
- Optional check valve
- Rotary knob with scale
- Optional lock

## Function description, sectional drawing

The 2FRM6 flow control valve is a two-way flow control valve. It is used to keep the constant flow and independent of pressure and temperature. The valve mainly consists of the valve body (1), rotary knob (2), orifice (3), pressure compensator (4) and an optional check valve.

**Flow control valve model:** 2FRM6B... -3X/ ...MV  
(without external closing, without check valve)

The flow from the oil port A to B is throttled at the throttle position (5). The throttle cross-section is adjusted by turning the rotary knob (2). In order to keep the flow constant and independent of pressure, a pressure compensator (4) is required to be installed in port B downstream of the throttle position (5).

The compression spring (6) presses the orifice (3) and pressure compensator (4) to their limited positions respectively and thus keeps the pressure compensator (4) in the open position when there is no flow through the valve. When the fluid flows through the valve, the pressure at port A acts to the pressure compensator (4) through the orifice (7). The pressure compensator (4) moves to the compensation position until force balance. If the pressure in oil port A increases, the pressure compensator (4) moves to the closed direction until the force balance is reached again.

Because the pressure compensator continuously acts as compensation, the flow can be maintained. In order to control the flow in both directions, the rectifier sandwich plate Z4S6 can be installed under the flow control valve.

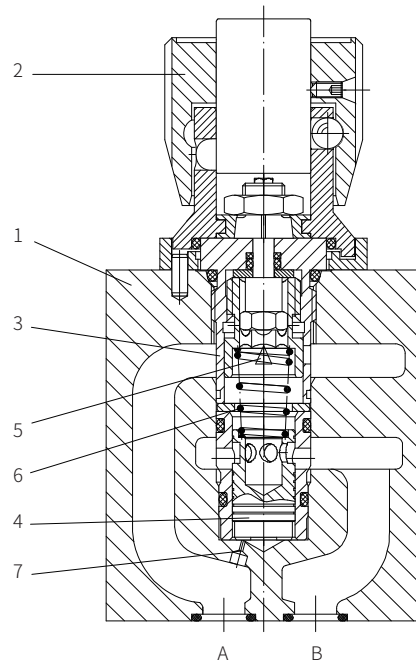

Model 2FRM6B76-3XJ/...M

## Function description, sectional drawing

This flow valve is provided with the possibility of an external closing of the pressure compensator (4) through channel P(9).

The external pressure acting in the channel (9) via orifice (10) to hold the pressure compensator (4) closed against the force of the spring (6). When the direction valve (11) in the middle position is switched from P to B, the valve can be used same load compensation function as model 2FRM6B to avoid the jump at start-up. This version with external closing of the compensator can only be used for the supply control. The fluid flows freely from port B to A through the check valve (8).

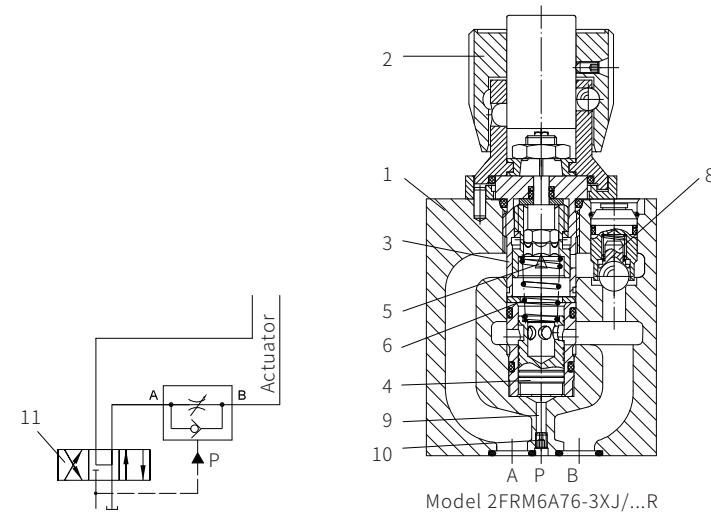

Model 2FRM6A76-3XJ/...R

## Functional symbols

Two ways flow control valve (simplified)

Without check valve  
without external closing

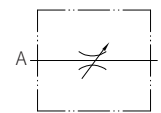

Model 2FRM6B...-3XJ/...M

With check valve  
without external closing

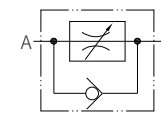

Model 2FRM6B...-3XJ/...R

Without check valve  
with external closing

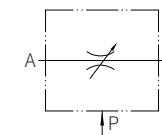

Model 2FRM6A...-3XJ/...M

With check valve  
with external closing

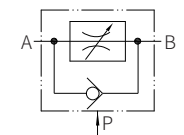

Model 2FRM6A...-3XJ/...R

Functional symbols

Two-way flow control valve (detailed)

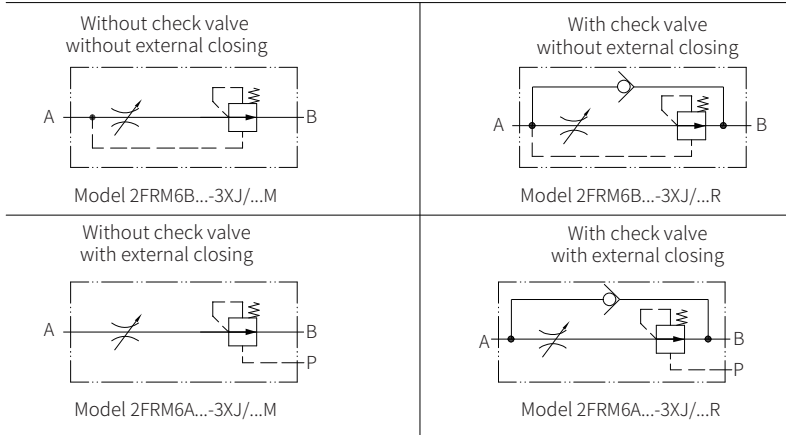

Rectifier sandwich plate (①= Valve side, ②= Subplate side)

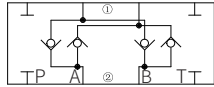

Model Z4S6-1XJ...

Models and specifications

Two ways flow control valve

2FRM 6 6 6 3X J V \*

two ways flow control valve =6  
size 6 =6  
with external closing of the pressure compensator (suppression of jump at start) without external closing of the pressure compensator =A  
adjusting element lockable rotary knob with scale =3  
rotary knob with scale =7  
zero position of marking at oil port P =6  
30 to 39 series (30 to 39 series installation and connection size unchanged) =3X  
Rekith =J

more information in text  
No code= no locating pin holes with locating pin holes  
No code = NBR seals  
V= FKM seals (consult for other seals)  
R= with check valve  
M= without check valve

sealing material  
No code = NBR seals  
V= FKM seals  
(consult for other seals)

flow (A→B)  
0.2Q= to 0.2L/ min  
0.6Q= to 0.6L/ min  
1.5Q= to 1.5L/ min  
3Q= to 3.0L/ min  
6Q= to 6.0L/ min  
10Q= to 10.0L/ min  
16Q= to 16.0L/ min  
25Q= to 25.0L/ min  
32Q= to 32.0L/ min

Models and specifications

Rectifier sandwich plate

Z4S6 1X J \*

rectifier sandwich plate size 6 =1X  
1X series (10 to 19 series installation and connection size unchanged) =1X  
Rekith =J

more information in text  
sealing material  
No code = NBR seals  
V= FKM seals  
(consult for other seals)

Technical parameters

Installation position	optional																																			
Environment temperature range	°C -20 to +50																																			
Weight	2FRM 6 A...; 2FRM 6 B... Kg about 1.3 2FRM 6 SB Kg about 1.5																																			
<b>Hydraulic</b>																																				
Maximum working pressure oil port A	bar 315																																			
Differential pressure for free flow from B to A	See characteristic curve																																			
Minimum pressure drop	bar 6 to 14																																			
Pressure stability at 315bar	% ±2(q <sub>v max</sub> )																																			
Flow	<table border="1"> <tr> <td>q<sub>v max</sub></td> <td>L/min</td> <td>0.2</td> <td>0.6</td> <td>1.5</td> <td>3.0</td> <td>6.0</td> <td>10.0</td> <td>16.0</td> <td>25.0</td> <td>32.0</td> </tr> <tr> <td>q<sub>v min</sub></td> <td>to 100 bar</td> <td>cm<sup>3</sup>/min</td> <td>15</td> <td>15</td> <td>15</td> <td>15</td> <td>25</td> <td>50</td> <td>70</td> <td>100</td> <td>250</td> </tr> <tr> <td>q<sub>v min</sub></td> <td>to 315 bar</td> <td>cm<sup>3</sup>/min</td> <td>25</td> <td>25</td> <td>25</td> <td>25</td> <td>25</td> <td>50</td> <td>70</td> <td>100</td> <td>250</td> </tr> </table>	q <sub>v max</sub>	L/min	0.2	0.6	1.5	3.0	6.0	10.0	16.0	25.0	32.0	q <sub>v min</sub>	to 100 bar	cm <sup>3</sup> /min	15	15	15	15	25	50	70	100	250	q <sub>v min</sub>	to 315 bar	cm <sup>3</sup> /min	25	25	25	25	25	50	70	100	250
q <sub>v max</sub>	L/min	0.2	0.6	1.5	3.0	6.0	10.0	16.0	25.0	32.0																										
q <sub>v min</sub>	to 100 bar	cm <sup>3</sup> /min	15	15	15	15	25	50	70	100	250																									
q <sub>v min</sub>	to 315 bar	cm <sup>3</sup> /min	25	25	25	25	25	50	70	100	250																									
Oil fluid	Mineral oil (HL, HLP) <sup>1)</sup> in accordance with DIN 51524; Fast living organisms degraded oil according to VDMA 24568; HETG (Rapeseed oil) <sup>1)</sup> HEPG(Polyethylene glycol) <sup>2)</sup> HEES (synthetic ester) <sup>2)</sup>																																			
Oil fluid temperature range	°C -20 to +80																																			
Viscosity range	mm <sup>2</sup> /s 10 to +800																																			
Cleanliness of oil	The maximum allowable pollution level of oil is ISO4406 Class 20/18/15																																			

1) The oil must meet the cleanliness degree requested by the components in the hydraulic system. Effective oil filtration can prevent failure and increase the service life of the components.  
Attention! There is a significant loss of pressure from port P of the valve to port A of the flow control valve.

## Characteristic curve

(Measured when using HLP 46,  $v_{oil} = 40^\circ\text{C} \pm 5^\circ\text{C}$ )

Relationship between flow and set scale (flow control from A to B)

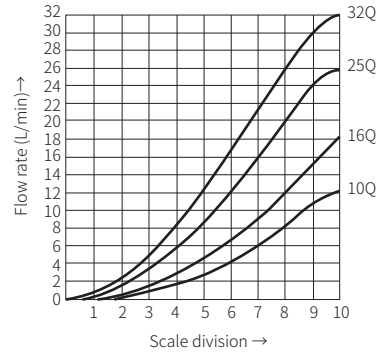
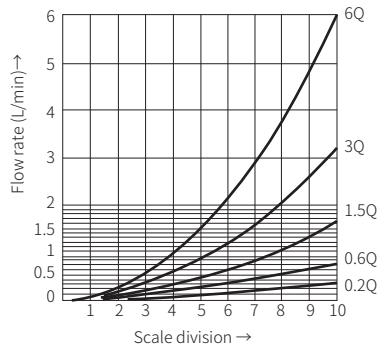

$\Delta p - q_v$ - Characteristic curve B to A  
throttle valve closed

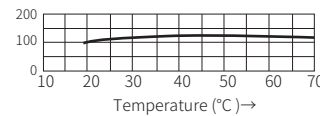
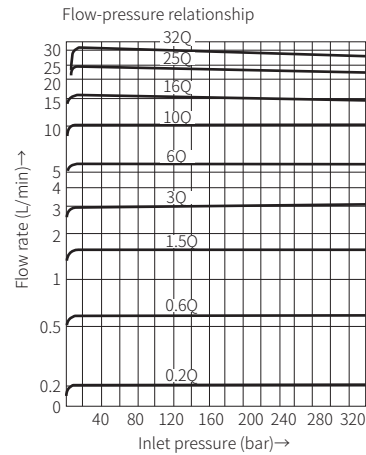
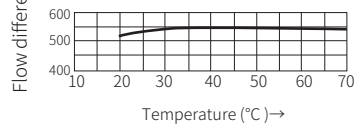
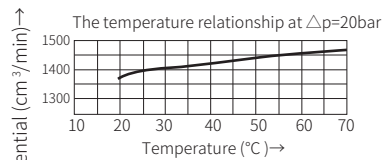
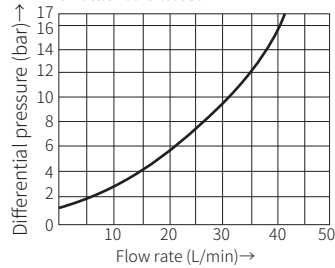

## Component size

Size unit: mm

Model 2FRM6...-3XJ/...

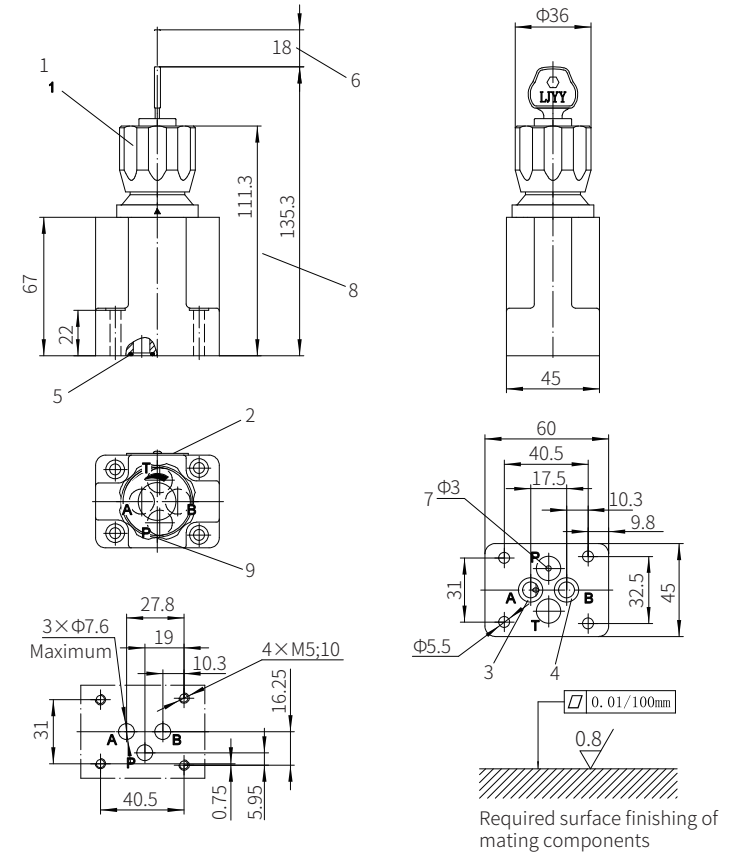

- 1 Lockable rotary knob with scale (adjusting form "3")
  - 2 Name plate
  - 3 Inlet oil port "A"
  - 4 Outlet oil port "B"
  - 5 O-ring 9.25x1.78 (for oil port A, B, P, T)
  - 6 Space required to remove key
  - 7 Hole for model 2FRM6B is not drilled (without external connection)
  - 8 Rotary knob with scale (adjusting form "7")
  - 9 Position of the marking at port P
- Valve fixing screw  
Without rectifier sandwich plate  
M5×30-10.9 grade GB/T70.1-2000  
Tightening torque  $M_A = 7.8\text{Nm}$   
With rectifier sandwich plate  
M5x70-10.9 grade GB/T70.1-2000  
Tightening torque  $M_A = 7.8\text{Nm}$
- Subplate model:  
G341/01 (G1/4")  
G342/01 (G3/8")  
G502/01 (G1/2")

## Component size

Size unit: mm

Rectifier sandwich plate Z4S6-1XJ/...

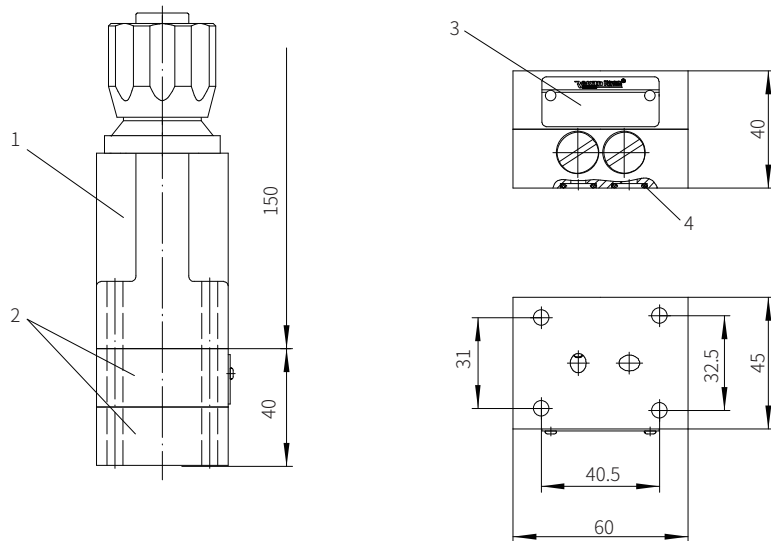

- 1 2-way flow control valve
- 2 Rectifier sandwich plate
- 3 Name plate
- 4 O-ring 9.25x1.78( for oil port A、 B)

**Attention:**

The rectifier sandwich plate type Z4S6-1XJ/... can not be connected with the flow control valve 2FRM6A...-3XJ/... with external connection of the pressure compensator.

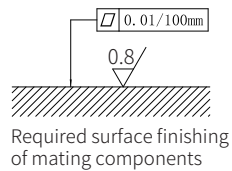

## Two Ways Flow Control Valve

Model: 2FRM...2XJ



- ◆ Size 10 to 16
- ◆ Maximum working pressure 315 bar
- ◆ Maximum working flow 160 L/ min

## Contents

Function description, sectional drawing	02
Models and specifications	03
Functional symbols	03
Technical parameters	04
Characteristic curve	05
Component size	06-07

## Features

- Optional pressure compensator stroke limiter
- Start-up jump reduction
- Lockable knob
- Flow control in both direction by means of rectifier sandwich plate