

Application examples

These examples only indicate some applications of the poppet valve but not include all functions.

	<p>2/2-way circuit Initial position: The flow is blocked and the pressure is held in the actuator even when the pump is turned off Switching position: The fluid flows freely and the maximum pressure is allowed.</p>		<p>2/2-way circuit Initial position: Lifting The maintenance of position only depends on the stroke limit and the pressure at port P. Switching position: Closed</p>
	<p>2/2-way circuit with two valves Initial position: The piston remains. Switching position: Move in both directions. The direction of movement depends on drives V1 and V2</p>		
	<p>3/2-way circuit Initial position: Side A remains logically closed Switching position: Side B remains logically closed</p>		
	<p>3/2-way circuit Initial position : Port P is closed, there is pressure at A and T, the piston of cylinder 1 moves to the right, and A is unloaded. The piston of cylinder 1 moves to the left. Switching position: Port T is closed, there is pressure at A and P. The piston of cylinder 2 moves to the left, and A is unloaded. The piston of cylinder 2 moves to the right.</p>		
	<p>4/2-way circuit with one 2/2-way and one 3/2-way poppet valve V1 and V2 in the initial position: the piston is blocked externally. V1 and V2 in switching position: the piston moves to the right. V1 in switching position and V2 in the initial position: the piston moves to the left. Both ends of the cylinder are connected with the pump port. Attention! When using single rod cylinders, the performance limit (double flow) of the valve and the maximum permissible working pressure (overpressure) must be taken into account!</p>		

Solenoid Operated Poppet Valve

Model: M-SED10...1XJ

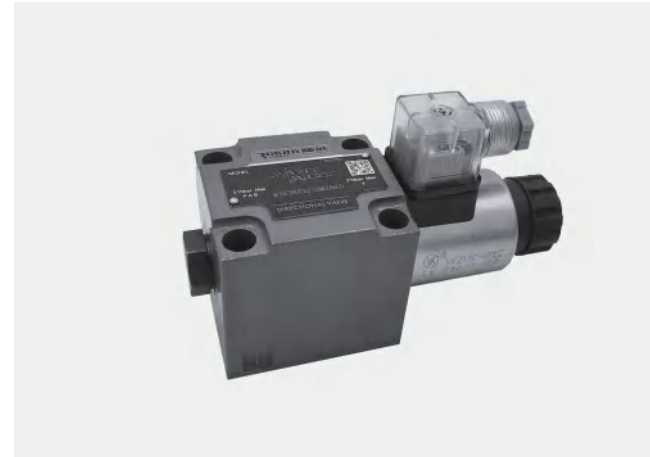

- ◆ Size10
- ◆ Maximum working pressure 350 bar
- ◆ Maximum working flow 40 L/min

Contents

Function description, sectional drawing	02-03
Models and specifications	04
Technical parameters	05
Characteristic curve	06
Characteristic limit	07
Component size	08-11
Application examples	12

Features

- Direct operated solenoid directional poppet valve
- Closed port without leakage
- Switching flexibility even in high-pressure state long periods
- Wet-pin DC solenoid with detachable coil(AC voltage available via rectifier)
- The solenoid coil can be rotated 90°
- Individual electrical connection
- Replacing the coil without opening the pressure chamber

Function description, sectional drawing

3/2-way directional poppet valve

General:

The M-SED10 directional valve is solenoid operated directional poppet valve, it is used to control the opening, closing and direction of oil.

The valve mainly consists of the valve body (1), solenoid (2) and closing element (4).

The manual emergency operation (6) can control the valve when the solenoid is not energized.

Basic functions:

The initial position of the valve is determined by the setting of the spring (5). When the power is cut off, the "UK" type valve is opened, while the "CK" type valve is closed. The valve chamber (3) behind the closing element (4) is connected to the port P and sealed against the port T. Therefore, the valve is in a pressure balanced state related to the operating force (solenoid and spring).

Due to the special closing element (4), the valve can work when the working pressures of ports P, A and T up to 350bar, and the flow in both directions (see symbols)! In the initial position, the closing element (4) is pressed onto the valve seat (11) by the spring (5), and in the switching position, the solenoid (2) pushes it towards the valve seat (7). That results in a leak-free seal.

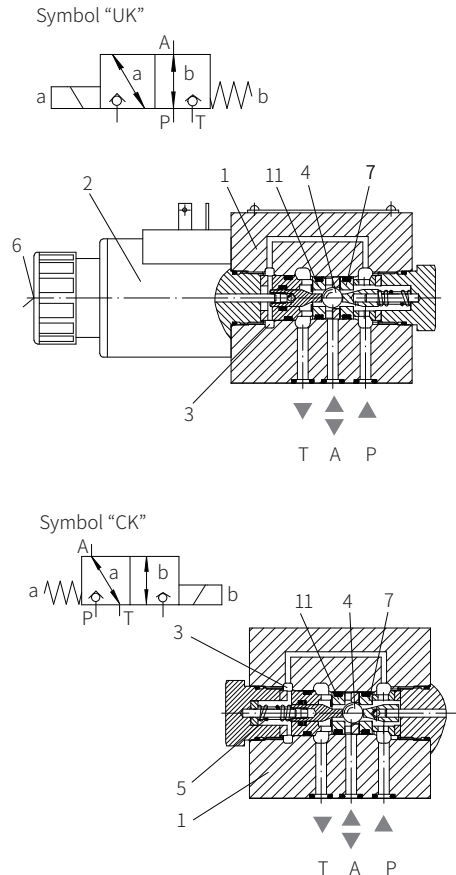

Function description, sectional drawing

4/2-way directional poppet valve

To install a sandwich plate, the plus-1 plate under the 3/2-way directional poppet valve, then it can be used as a 4/2-way directional poppet valve.

Function of plus-1 plate:

Initial position:

The main valve does not work. The spring (5) holds the closing element (4) on the valve seat (11). The port P is closed, and port A is connected to port T. In addition, there is a control line over a large area from A to the control piston (8), which unloads to the tank. The pressure oil provided by the the oil port P pushes the ball (9) to the valve seat (10), then P is connected to B and A to T.

Transition position:

When the main valve is operated, the closing element (4) overcomes the force of the spring (5) and presses on the valve seat (7). Therefore, the oil

port T is closed, the ports P, A and B are connected to each other within a short time.

Switching position:

The port P is connected to A. The pressure oil from the pump acts on the large area of the control piston (8) through A, and the ball (9) is pushed to the valve seat (12). Therefore, B is connected to T and P to A. The ball (9) in the plus-1 plate has a "positive covering switching function". In order to avoid a sudden increase in pressure when using a single rod cylinder, the annular area of the cylinder must be connected to A.

Because of the using of the plus-1 plate and the different arrangement of the valve seat, the following situations may occur.

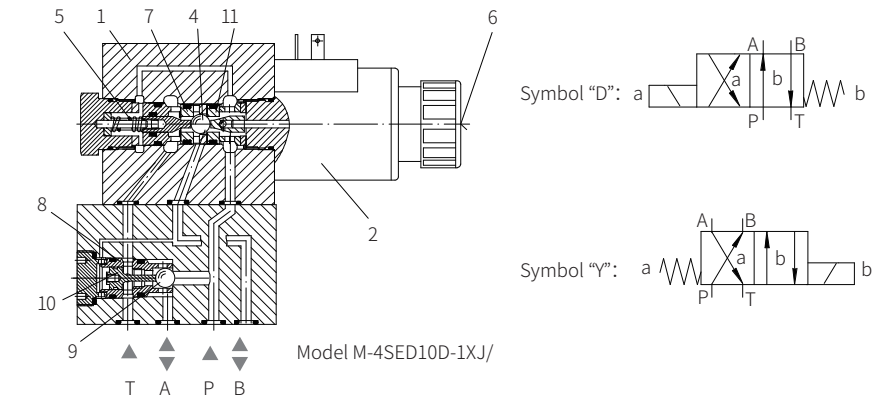

Cartridge throttle

Due to the working conditions limitations, it may occur that the flow exceeds the performance limit of the valve during the switching process, then the use of a throttle is required.

Example:

- Accumulator operation
- Used as a pilot valve with internal pilot oil supply

3/2-way poppet valve

The throttle is inserted into the port P of the directional valve.

4/2-way poppet valve

The throttle is inserted into the oil port P of the plus-1 plate.

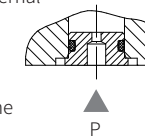

Cartridge check valve

The cartridge check valve allows free flow from P to A and leak-free closure from A to P.

3/2-way poppet valve

The cartridge check valve is inserted into the oil port P of the directional valve.

4/2-way poppet valve

The cartridge check valve is inserted into port P of the plus-1 plate.

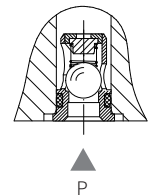

Models and specifications

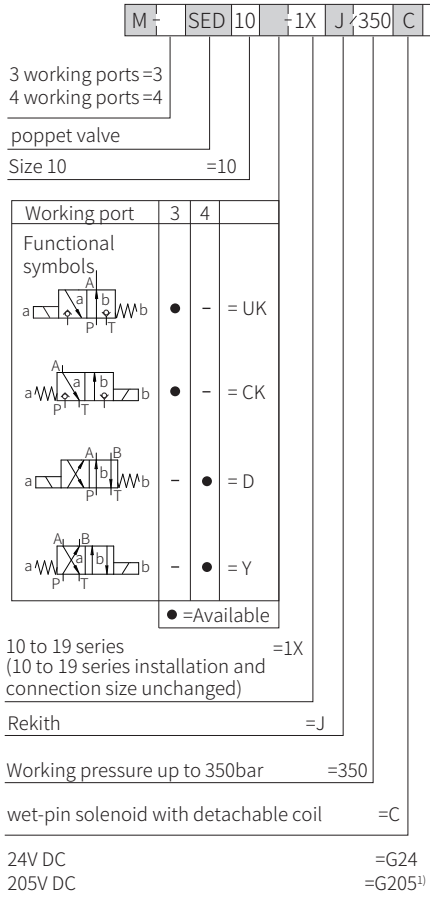

more information in text
sealing material
No code= NBR seals
V= FKM seals
(consult for other seals)

No code= without cartridge throttle
valve and cartridge
with cartridge check valve
B12= throttle Ø1.2mm
B15= throttle Ø1.5mm
B18= throttle Ø1.8mm
B20= throttle Ø2.0mm
B22= throttle Ø2.2mm

electrical connection
K4= no insert plug
Z5L= large right angle lamp plug

N9= with hidden manual emergency operation
No code= no manual emergency operation

1)When using AC power supply to DC solenoid, the voltage must be rectified by a rectifier.

Technical parameters

Overview													
Installation position	Optional												
Environmental temperature range	°C	-30 to +50 (NBR seal) -20 to +50 (FKM seal)											
Weight	3/2-way valve	kg	2.6										
	4/2-way valve	kg	3.9										
Hydraulic													
Maximum working pressure	bar	See characteristic limit											
Maximum flow	L/min	40											
Hydraulic oil	Mineral oil (HL, HLP) ¹⁾ in accordance with DIN 51524; Fast living organisms degraded oil according to VDMA 24568; HETG (Rapeseed oil) ¹⁾ ; HEPG(Polyethyleneglycol) ²⁾ ; HEES (Synthetic Fats) ²⁾												
Oil temperature range	°C	-30 to +80 (NBR seal) -20 to +80 (FKM seal)											
	mm ² /s	2.8 to 500											
Viscosity range	2.8 to 500												
Cleanliness of oil ⁴⁾	The maximum allowable pollution level of oil is ISO4406 Class 20/18/15												
Electrical													
Voltage type		DC	AC										
Available voltage ³⁾	V	24, 205	Only available via rectifier										
Allowable voltage tolerance (nominal voltage)	%	±10											
Power consumption	W	30											
Continuous power on time	Continuous												
Switching time according to ISO6403	See table below												
Switching frequency	times/hour	15000											
Protection type according to DIN 40050	IP65 with plug installed and fixed												
Maximum coil temperature	°C	150											
1) Suitable for NBR seal and FKM seal		4) The oil must meet the cleanliness degree requested by the components in the hydraulic system.											
2) Only suitable for FKM seals		Effective oil filtration can prevent failure and increase the service life of the components.											
3) Please inquire for special voltages													
Switching time t _{ms} (installation position: solenoid installed horizontally)		Electrical protective conductor (PE +) must be connected properly as rules											
Pressure P bar	Flow q _v L/min	DC Solenoid						AC Solenoid + Rectifier					
		Functional symbols UK, CK, D, Y						Functional symbols UK, CK, D, Y					
		t _{on} No tank pressure		t _{off}		t _{on} No tank pressure		t _{off}		t _{on} No tank pressure		t _{off}	
		UK	CK	D	Y	UK/CK	D/Y	UK	CK	D	Y	UK/CK	D/Y
70	40	40	30	40	35	10	10	35	30	40	35	40	40
140	40	40	30	40	35	10	10	40	30	40	35	40	40
210	40	45	35	45	35	10	10	45	35	45	35	40	40
280	40	45	35	45	35	10	10	45	35	45	35	40	40
315	40	50	35	50	35	10	10	50	40	50	40	40	40
350	40	50	45	50	45	10	10	50	45	50	45	40	40

Note: Switching time is related to flow direction P to A and A to T. There may be bias in reverse flow.

Characteristic curve

(Measured when using HLP46, $\vartheta_{oil} = 40^\circ\text{C} \pm 5^\circ\text{C}$)

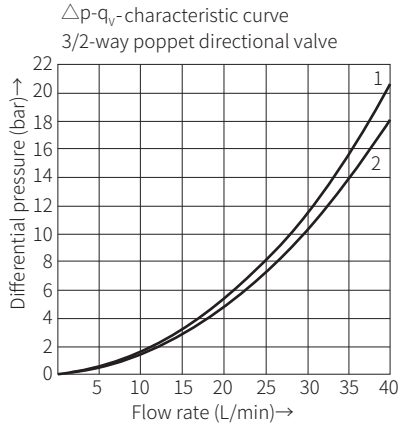

1M-3SED10 CK ..., PtoA
2M-3SED10 UK CK ..., AtoT

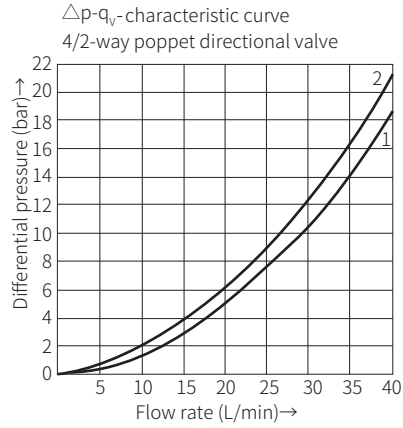

1M-4SED10 D Y ..., PtoB, AtoT
2M-4SED10 D Y ..., BtoT, PtoA

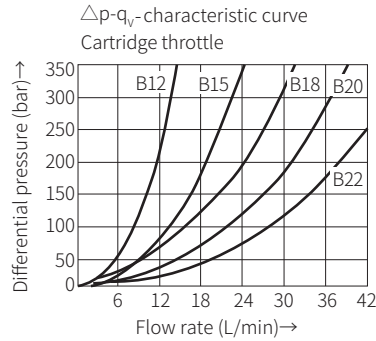
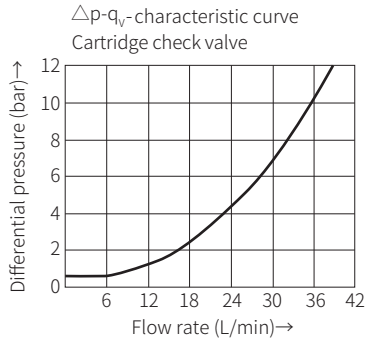

Characteristic limit

(Measured when using HLP46, $\vartheta_{oil} = 40^\circ\text{C} \pm 5^\circ\text{C}$)

	Functional symbol	comment	Working pressure bar				Flow
			P	A	B	T	
Two-way circuit	"UK" 	The port P or T needs to be blocked by the customer when 2/2-way circuit used!	350	350		350	40
	"CK" 		350	350		350	40
Three-way circuit	"UK" 		350	350		350	40
	"CK" 		350	350		350	40
Four-way circuit flow only in the direction of the arrow	"D" 	3/2-way directional valve (symbol "UK") with plus-1 plate $P \geq A \geq B \geq T$	350	350	350	P/A/B-40	40
	"Y" 	3/2-way directional valve (symbol "CK") with plus-1 plate $P \geq A \geq B \geq T$	350	350	350	P/A/B-40	40

Notice!
The characteristic limit is measured when the solenoid is at operating temperature, at 10% below the standard voltage and without tank preloading.

Component size

Size unit: mm

3/2-way poppet directional valve "UK"

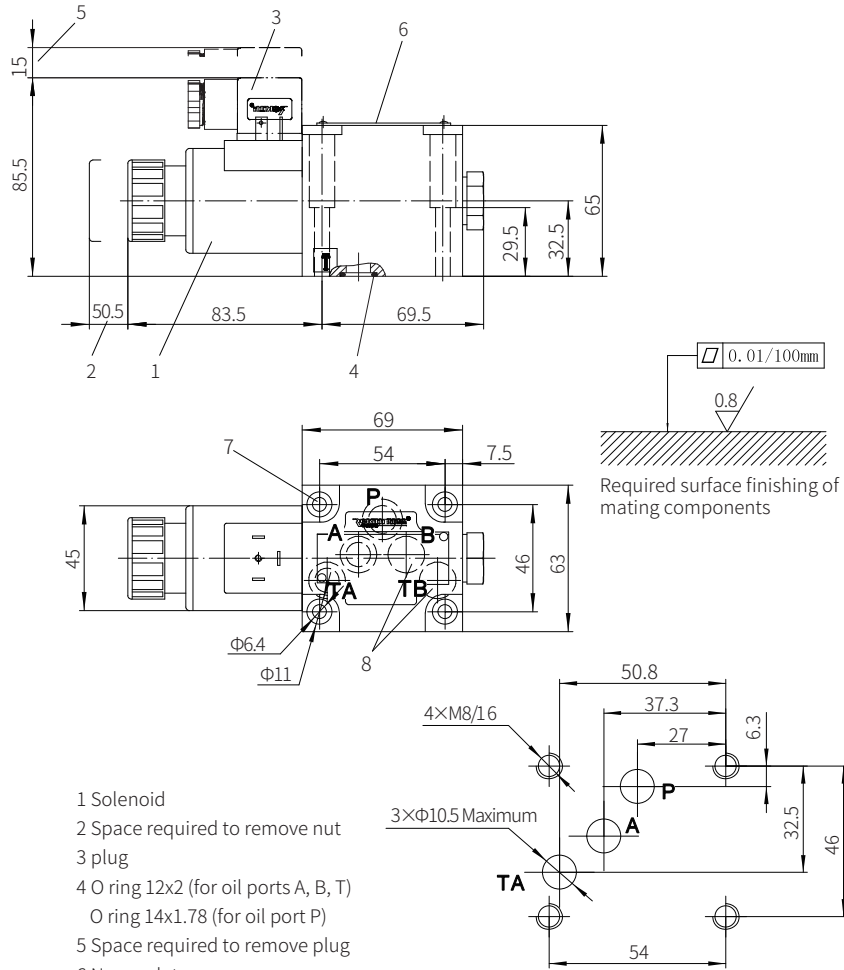

- 1 Solenoid
- 2 Space required to remove nut
- 3 plug
- 4 O ring 12x2 (for oil ports A, B, T)
O ring 14x1.78 (for oil port P)
- 5 Space required to remove plug
- 6 Name plate
- 7 Screw fixing holes
- 8 B and TB are blind holes

Valve fixing screw
M6x40-10.9 grade GB/T70.1-2000
Tightening torque $M_A=13.7\text{Nm}$

It must be ordered separately
if connection subplate is needed.
Subplate model:
G66/01 (G3/8"); G66/02 (M18x1.5)
G67/01 (G1/2"); G67/02 (M22x1.5)

Component size

Size unit: mm

3/2-way poppet directional valve "CK"

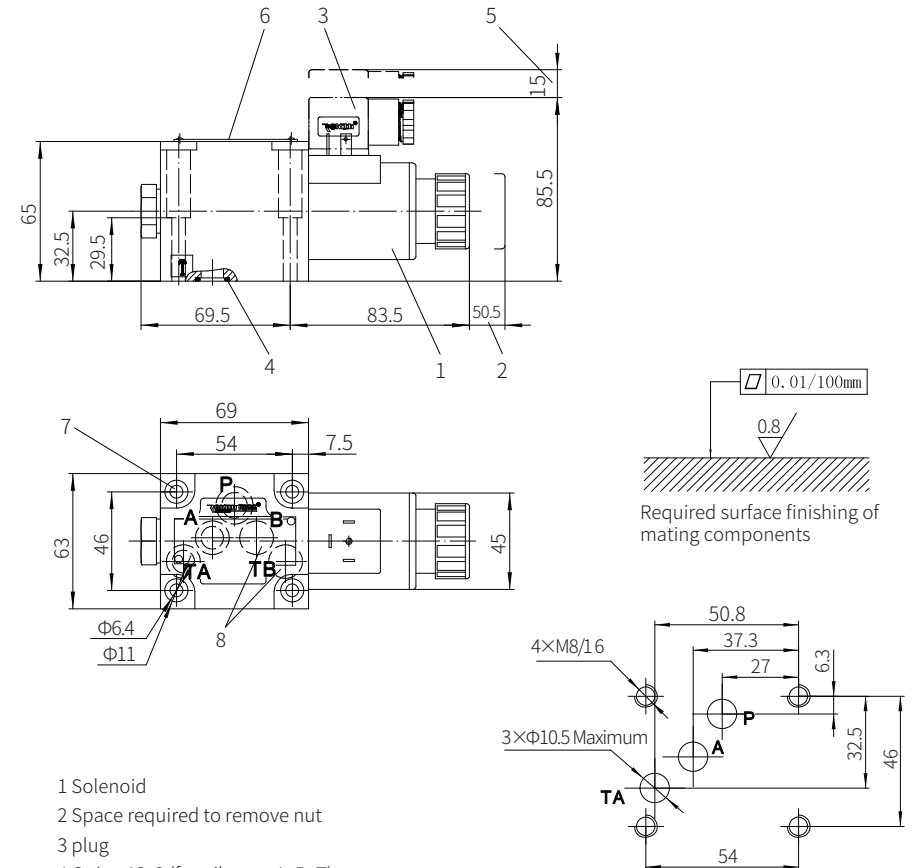

- 1 Solenoid
- 2 Space required to remove nut
- 3 plug
- 4 O ring 12x2 (for oil ports A, B, T)
O ring 14x1.78 (for oil port P)
- 5 Space required to remove plug
- 6 Name plate
- 7 Screw fixing holes
- 8 B and TB are blind holes

Valve fixing screw
M6x40-10.9 grade GB/T70.1-2000
Tightening torque $M_A=13.7\text{Nm}$

It must be ordered separately
if connection subplate is needed.
Subplate model:
G66/01 (G3/8"); G66/02 (M18x1.5)
G67/01 (G1/2"); G67/02 (M22x1.5)

Component size

Size unit: mm

4/2-way poppet directional valve "D"

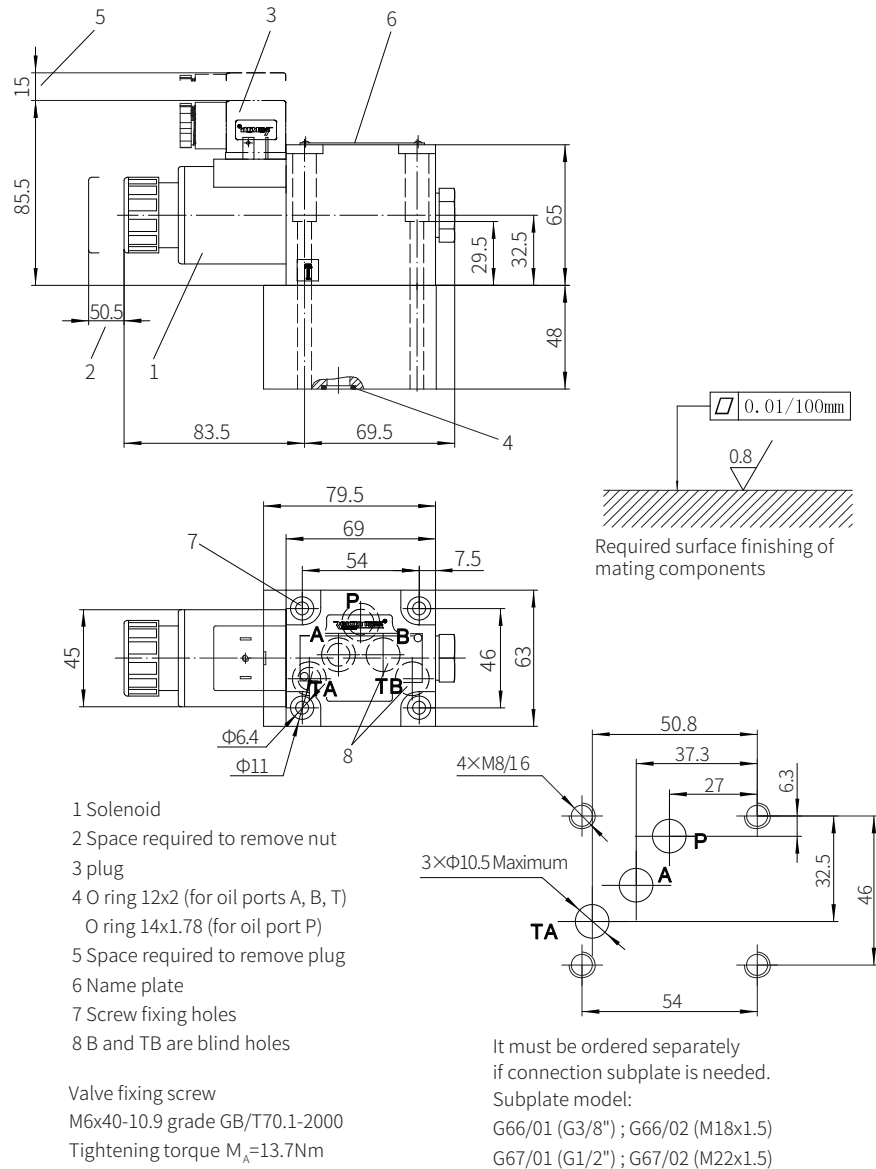

0220

Component size

Size unit: mm

4/2-way poppet directional valve "Y"

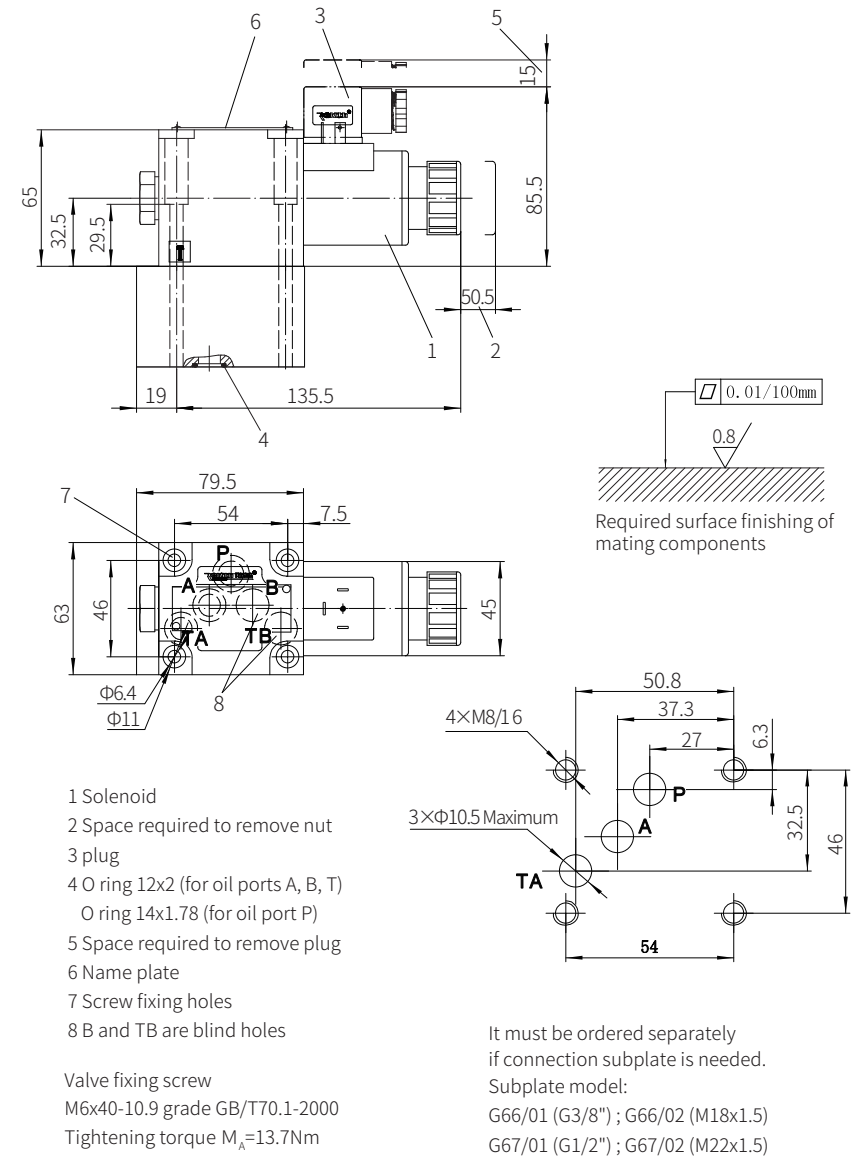

0221

Application examples

These examples only indicate some applications of the poppet valve but not include all functions.

	<p>2/2-way circuit Initial position: The flow is blocked and the pressure is held in the actuator even when the pump is turned off. Switching position: The fluid flows freely and the maximum pressure is allowed.</p>		<p>2/2-way circuit Initial position: Lifting The maintenance of position only depends on the stroke limit and the pressure at port P. Switching position: Closed.</p>
	<p>2/2-way circuit with two valves Initial position: The piston remains. Switching position: Move in both directions. The direction of movement depends on drives V1 and V2.</p>		
	<p>3/2-way circuit Initial position: Side A remains logically closed Switching position: Side B remains logically closed</p>		
<p>Symbol "CK"</p>	<p>3/2-way circuit Initial position: Port P is closed, there is pressure at A and T. The piston of cylinder 1 moves to the right, and A is unloaded. The piston of cylinder 1 moves to the left. Switching position: Port T is closed, there is pressure at A and P. The piston of cylinder 2 moves to the left, and A is unloaded. The piston of cylinder 2 moves to the right.</p>		
<p>Symbol "2/2"+"UK"</p>	<p>4/2-way circuit with one 2/2-way and one 3/2-way poppet valve V1 and V2 in the initial position: the piston is blocked external. V1 and V2 in switching position: the piston moves to the right. V1 in switching position and V2 in the initial position: the piston moves to the left. Both ends of the cylinder are connected with the pump port. Attention! When using single rod cylinders, the performance limit (double flow) of the valve and the maximum permissible working pressure (overpressure) must be taken into account!</p>		

Hydraulic or Electro-hydraulic Directional Valve

Model: WEH/WH...5XJ



- ◆ Size 10~32
- ◆ Maximum working pressure 350 bar
- ◆ Maximum working flow 1100 L/min

Contents

Function description, sectional drawing	02 - 04
Models and specifications	05
Functional symbols	06-08
Technical parameters	09-10
Characteristic curve	11-13
Characteristic limit	11-13
Switching time adjustment, pressure reducing valve and pre-load valve	14
Component size	15-20

Features

- Mainly used to control the opening, closing and direction of liquid flow
- Electro-hydraulic operation (WEH)
- Hydraulic operation (WH)
- Subplate mounting
- The mounting surface according to DIN24340 form A and ISO4401
- Spring or hydraulic centered
- Spring or hydraulic return to initial position
- Wet-pin DC or AC solenoid
- Optional manual emergency operation
- Individual or central electrical connection
- Optional switching time adjustment
- Optional pre-load valve in port P of the main valve
- Auxiliary component, optional
- Stroke adjustment of main spool
- Stroke adjustment or end position sensor
- Inductive or mechanical limit switch (proximity type) of the main spool