

Component size

Size unit: mm

Model WHD10...3XJ/...

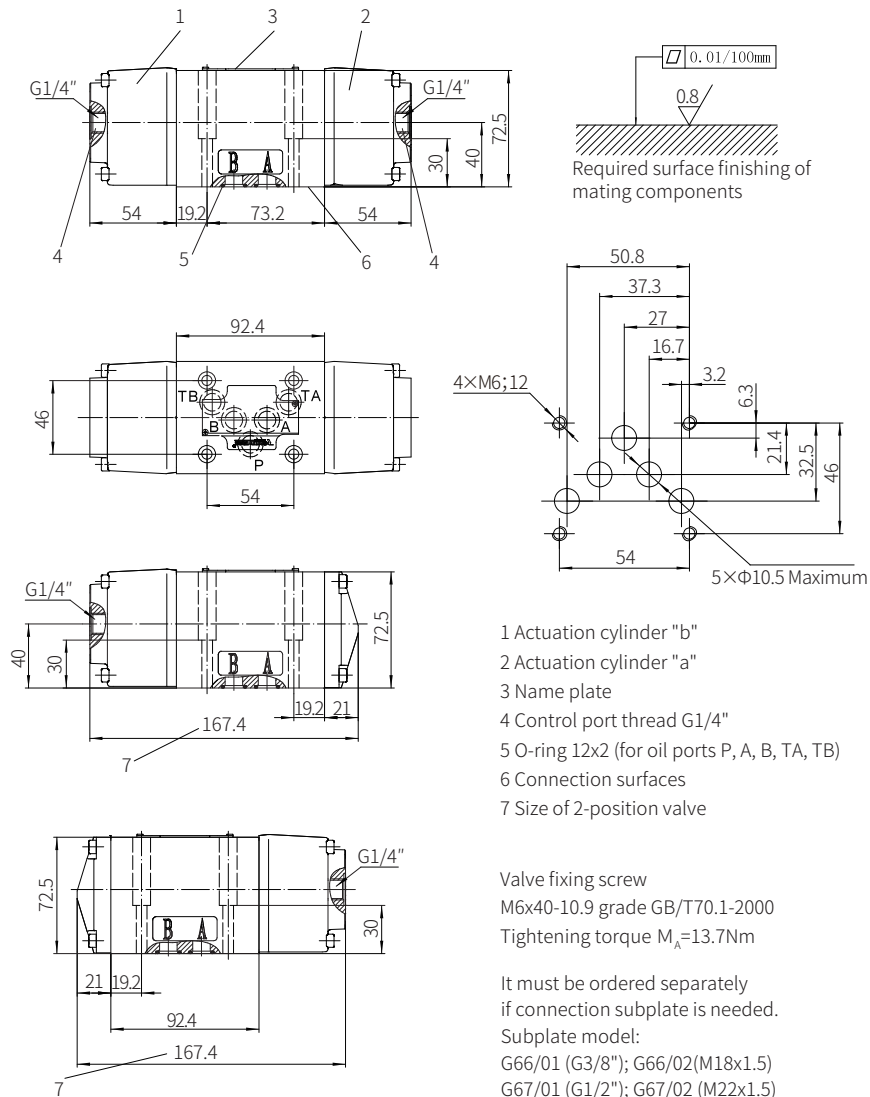

0178

Solenoid Operated Poppet Valve

Model: M-SEW6...3XJ



- ◆ Size 6
- ◆ Maximum working pressure 420/630 bar
- ◆ Maximum working flow 25 L/min

Contents

Function description, sectional drawing	02-03
Models and specifications	04
Technical Parameters	05
Characteristic curve	06
Characteristic limit	07
Component size	08-09
Application examples	10

Features

- Direct operated solenoid directional poppet valve
- Closed port without leakage
- Switching smoothly even in high-pressure state long periods

0179

Function description, sectional drawing

General:

The M-SEW6 directional valve is solenoid operated directional seat valve. It is used to control the opening, closing and flow direction of fluid.

The valve is mainly composed of valve body (1), solenoid (2), hardened valve system (3) and ball (4) as the closing element.

Basic functions:

In the initial position, the ball (4) is pressed into the valve seat by the spring (9) and by the solenoid (2) when in the switching position. The force of the solenoid (2) acts on the actuating push rod (8) which is sealed on both sides through the lever (6) and the ball (7). The chamber between the two sealing elements is connected to oil port P. Therefore, the valve system is pressure compensated based on the actuating force (solenoid or reset spring). In this way, the valve can be used up to 630bar.

Note:

The 3/2-way directional seat valve has "negative cover" function. Therefore, port T must be always connected. That means the ports P-A-T are connected with each other during the switching process (from the starting of the opening of one valve seat to the closing of the other valve seat). But this process is completed in a very short time, so it is irrelevant in almost all applications. The manual emergency operation (10) allows the valve to be switched without solenoid energized. It must ensure that the specified maximum flow is not exceeded! If necessary, a throttle can be used to limit the flow.

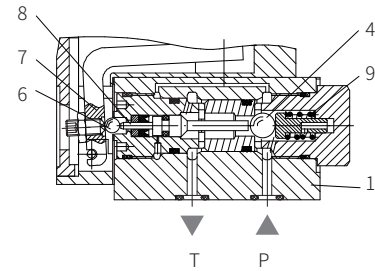

Model M-2SEW6N...3XJ/

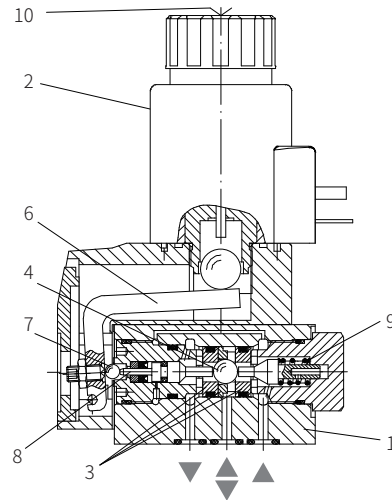

Model M-3SEW6U...3XJ/

2/2-way directional seat valve	
Symbol "P"	
Initial position	P and T connected
Switching position	P blocked
Symbol "N"	
Initial position	P blocked
Switching position	P and T connected

3/2-way directional seat valve	
Symbol "U"	
Initial position	P and A connected, T blocked
Switching position	P blocked, A and T connected
Symbol "C"	
Initial position	P blocked, A and T connected
Switching position	P and A connected, T blocked

Function description, sectional drawing

To install a sandwich plate, the plus-1 plate under the 3/2 directional seat valve, the function of a 4/2-way directional seat valve can be realized.

Function of plus-1 plate:

Initial position:

The main valve does not work. The spring (9) holds the ball (4.1) on the valve seat (11). The port P is blocked, and port A is connected to port T. In addition, there is a pilot line connected from A to the large area of the control spool (12), which is unloaded to the tank. The pressure provided by port P will push the ball (13) to the valve seat (14). Now, P is connected to B, and A to T.

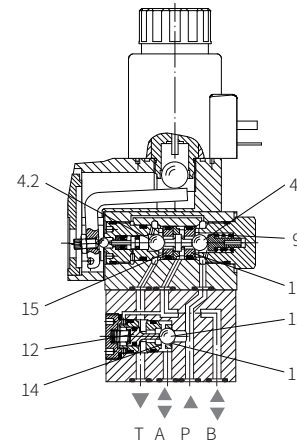

Model M-4SEW6D...3XJ/

Transition position:

When the main valve is operated, the spool (4.2) moves against the spring (9) and is pressed into the valve seat (15). During this process, port T will be closed, P, A and B are connected to each other within a short time.

Switching position:

The port P is connected to A. The pump pressure acts via A on the large area of the control spool (12), the ball (13) is pressed into the valve seat (16). Therefore, B is connected to T and P to A. The balls (13) in the plus-1 plate has "positive cover".

Note:

In order to avoid pressure intensification when the single rod cylinders used, the annular area of the cylinder must be connected to A.

The seat valve with plus-1 plate as below:

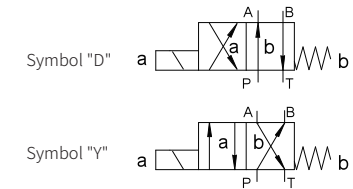

Cartridge throttle

Due to the working conditions limitations, it may occur that the flow exceeds the performance limit of the valve during the switching process, then the use of a throttle is required.

Example:

- Accumulator operation
- Used as a pilot valve with internal pilot oil supply

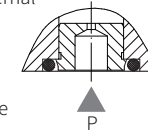

3/2-way poppet valve

The throttle is inserted into the port P of the directional valve.

4/2-way poppet valve

The throttle is inserted into the oil port P of the plus-1 plate.

Cartridge check valve

The cartridge check valve allows free flow from P to A and leak-free closure from A to P.

3/2-way poppet valve

The cartridge check valve is inserted into the oil port P of the directional valve.

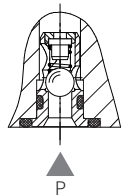

4/2-way poppet valve

The cartridge check valve is inserted into port P of the plus-1 plate.

Models and specifications

M	SEW	6	3X	J	M	K4	*
---	-----	---	----	---	---	----	---

2 working ports=2
3 working ports=3
4 working ports=4

poppet valve
size 6

working port	2	3	4	
	●	-	-	=P
	●	-	-	=N
	-	●	-	=U
	-	●	-	=C
	-	-	●	=D
	-	-	●	=Y

●=available

30 to 39 series =3X
(30 to 39 series installation and connection size unchanged)

Rekith =J

working pressure up to 420 bar (fixing screw M5) =420
working pressure up to 630 bar (fixing screw M6) =630

solenoid with detachable coil (air-gap) =M

more information in text

sealing material
No code= NBR seals
V= FKM seals
(consult for other seals)

without cartridge throttle and cartridge check valve
P= with cartridge check valve
B12= throttle Ø1.2mm
B15= throttle Ø1.5mm
B18= throttle Ø1.8mm
B20= throttle Ø2.0mm
B22= throttle Ø2.2mm

electrical connections
K4= no insert plug
Z5L= large right angle lamp plug

no manual emergency operation
N9= with hidden manual emergency operation

G24= 24VDC
G205= 205VDC

01

Technical parameters

Overview													
Environment temperature range	°C	-30 to +50 (NBR seal) -20 to +50 (FKM seal)											
Weight	2/2-way valve	kg	1.5										
	3/2-way valve	kg	1.5										
	4/2-way valve	kg	2.3										
Hydraulic													
Maximum working pressure	bar	See characteristic limit											
Maximum flow	L/min	25											
Pressure medium		Mineral oil (HL, HLP) ¹⁾ in accordance with DIN 51524; Fast living organisms degraded oil according to VDMA 24568; HETG (Rapeseed oil) ²⁾ ; HEPG(Polyethyleneglycol) ²⁾ ; HEES (Synthetic Fats) ²⁾											
1) For NBR and FKM seal													
2) Only for FKM seal													
Pressure medium temperature range	°C	-30 to +80 (NBR seal) -20 to +80 (FKM seal)											
Viscosity range	mm ² /s	28 to 500											
Cleanliness of oil ³⁾		The maximum allowable pollution level of oil is ISO4406 Class 20/18/15											
Electrical													
Voltage type		DC	AC										
Available voltage	V	24、205	Only available via rectifier										
Allowable voltage tolerance (nominal voltage) %		±10											
Power consumption	W	30											
Continuous power on time	%	100											
Switch time to ISO 6403		See below table											
Switching frequency	times/hour	15000 (working pressure ≤ 350bar)/3600 (working pressure ≥ 350bar)											
Protection type to DIN 40050		IP65 with plug installed and fixed											
Maximum coil temperature	°C	150											
3) The oil must meet the cleanliness degree requested by the components in the hydraulic system. Effective oil filtration can prevent failure and increase the service life of the components.													
4) Please inquire for special voltages													
			Electrical protective conductor (PE) must be connected properly as rules										
Switching time tms (Installation position: solenoid installed horizontally)													
Pressure P bar	Flow q _v L/min	DC Solenoid						AC Solenoid + Rectifier					
		Functional symbol U, C, D, Y											
		Functional symbol U, C, D, Y						Functional symbol U, C, D, Y					
		t _{on} No tank pressure				t _{off}		t _{on} No tank pressure				t _{off}	
		U	C	D	Y	U/C	D/Y	U	C	D	Y	U/C	D/Y
140	25	25	30	25	30	10	10	30	40	30	40	35	35
280	25	25	30	25	30	10	10	35	45	35	45	40	40
320	25	25	35	25	35	10	10	35	50	35	50	40	40
420	25	25	35	25	35	10	10	40	50	40	50	50	50
500	25	25	40	25	40	10	10	40	55	40	55	50	50
600	25	25	40	25	40	10	10	40	55	40	55	55	55

01

Characteristic curve

(Measured when using HLP46, $\vartheta_{oil}=40^{\circ}\text{C} \pm 5^{\circ}\text{C}$)

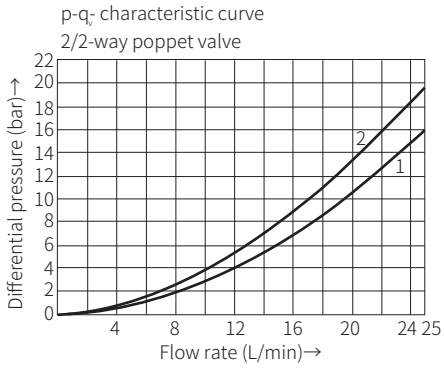

- 1 M-2SEW6N...P to T
- 2 M-2SEW6P...P to T

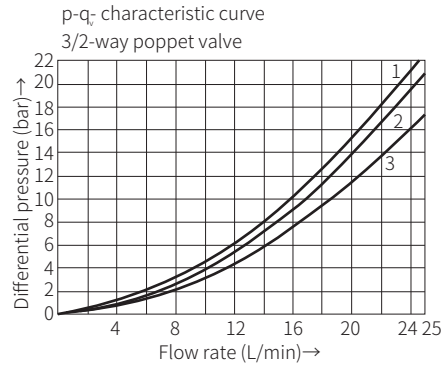

- 1 M-3SEW6^U_C...A to T
- 2 M-3SEW6U...P to A
- 3 M-3SEW6C...P to A

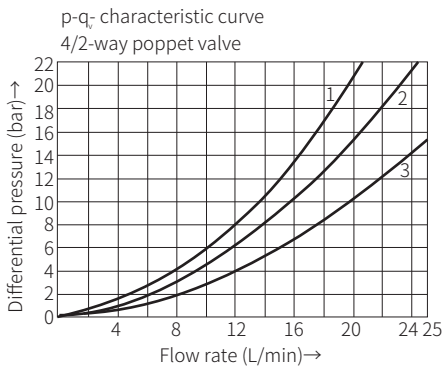

- 1 M-4SEW6^D_V...A to T
- 2 M-4SEW6^D_V...P to A
- 3 M-4SEW6^D_V...P to B, B to T

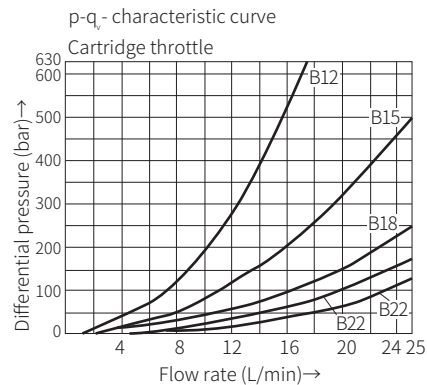
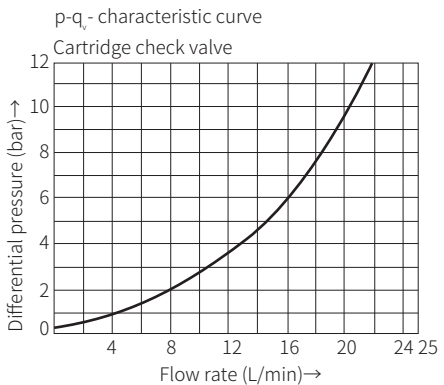

Characteristic limit

	Functional symbol	comment	Working pressure bar				Flow L/min
			P	A	B	T	
Two-way circuit		Oil port pressure $P \geq T$	420/630			100	25
			420/630			100	25
Three-way circuit		Oil port pressure $P \geq A \geq T$	420/630	420/630		100	25
			420/630	420/630		100	25
Two-way circuit (only for unloading function)		Pressure must be maintained in port A before switching from the original position to the switching position. Oil port pressure $A \geq T$		420/630		100	25
		Oil port pressure $A \geq T$		420/630		100	25
Four-way circuit (flow only in the direction of the arrow)		Single poppet valve (symbol "U") with plus-1 plate $P \geq A \geq B \geq T$	420/630	420/630	420/630	100	25
		Double poppet valve (symbol "C") with plus-1 plate $P \geq A \geq B \geq T$	420/630	420/630	420/630	100	25

Note:

- In order to operate the valve safely or keep it in the switching position, the oil port pressure $P \geq A \geq T$ (based on the structure).
 - The ports P, A and T (3/2-way valve), and ports P, A, B and T (4/2-way valve) are configured according to their functions and must not be blocked or used in other ways. Liquid flow is only allowed in the direction of the arrow.
 - When using the plus-1 plate (4/2-way valve), the following data must be met: $P_{min}=8\text{bar}$; $Q>3\text{ L/min}$
 - The specified maximum flow should not be exceeded.
- The characteristic limit is measured when the solenoid is at operating temperature, at 10% below the standard voltage and without tank preloading.

Component size

Size unit: mm

2/2 and 3/2-way poppet directional valve

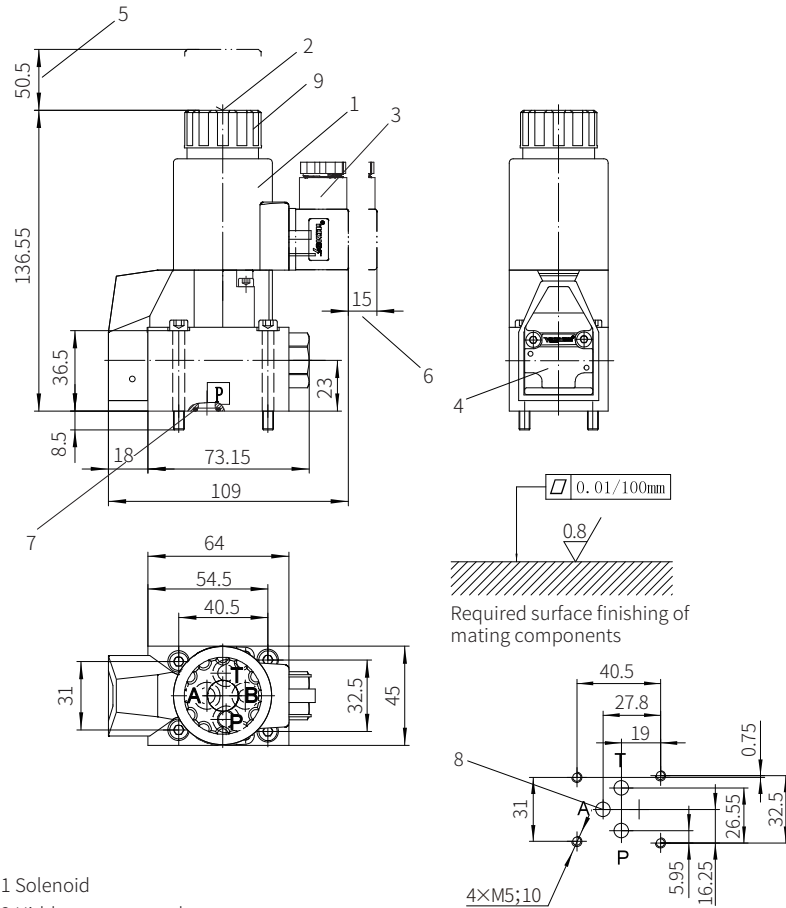

- 1 Solenoid
- 2 Hidden emergency button
- 3 Plug
- 4 Name plate
- 5 Space required to remove the coil
- 6 Space required to remove the plug
- 7 O-ring 10x2 (for oil port P)
O-ring 9.25x 1.78 (for oil ports B, A, T) 420bar type
O-ring 9.25X 1.78 (for oil ports B, A, T) 630bar type
- 8 Port A and B are blind holes for 2/2-way valve
Port B is a blind hole for 3/2-way valve

Valve fixing screw
Version 420 bar:
M5x50-10.9 grade GB/T70.1-2000
Tightening torque $M_A=7.8\text{Nm}$
Version 630 bar:
M6x45-10.9 grade GB/T70.1-2000
Tightening torque $M_A=13.7\text{Nm}$

Component size

Size unit: mm

4/2-way poppet directional valve

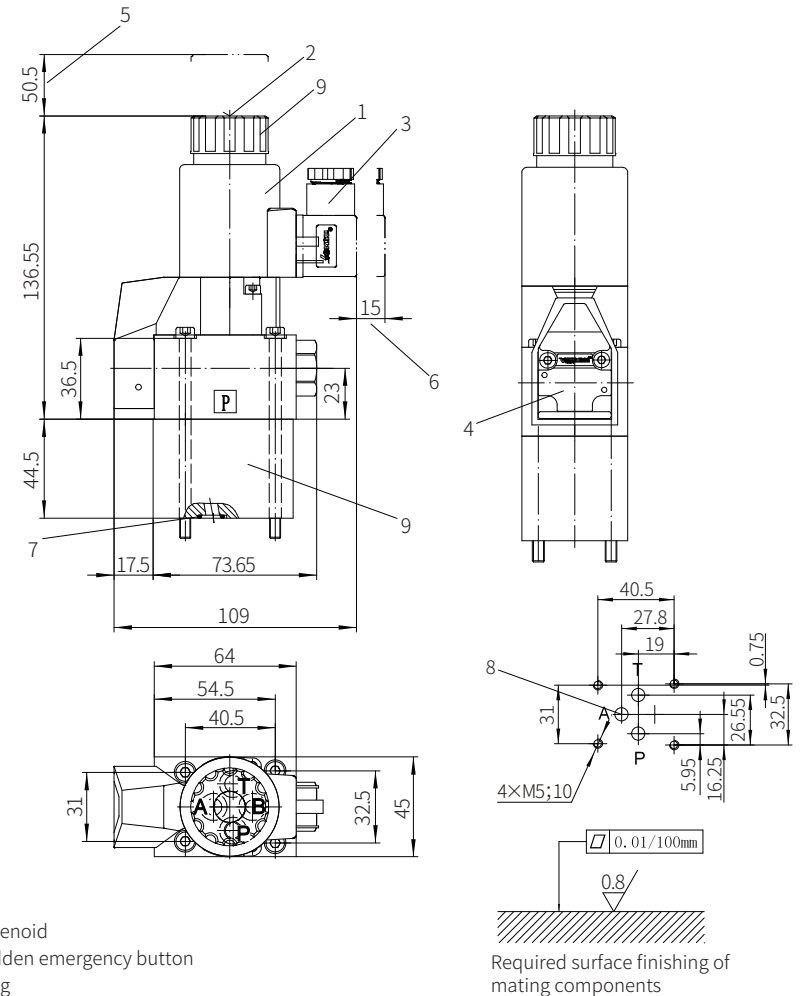

- 1 Solenoid
- 2 Hidden emergency button
- 3 Plug
- 4 Name plate
- 5 Space required to remove the coil
- 6 Space required to remove the plug
- 7 O-ring 10X2 (for oil port P)
O-ring 9.25X1.78 (for oil ports B, A, T)
- 8 Port A and B are blind holes for 2/2-way valve
Port B is a blind hole for 3/2-way valve
- 9 Plus-1 plate

Valve fixing screw
Version 420 bar:
M5x50-10.9 grade GB/T70.1-2000
Tightening torque $M_A=7.8\text{Nm}$
Version 630 bar:
M6x45-10.9 grade GB/T70.1-2000
Tightening torque $M_A=13.7\text{Nm}$

Application examples

These examples only indicate some applications of the poppet valve but not include all functions.

<p>Symbol C</p>	<p>Symbol U</p> <p>3/2-way circuit with a single poppet valve Initial position: Lifting The maintenance of position only depends on the stroke limit and the pressure at port P. Switching position: Descending</p>
<p>Symbol U</p> <p>2/2-way circuit with a single poppet valve and check valve at port A The check valve must be installed on the pipeline. Initial position: The fluid flows freely and the maximum pressure is allowed. Due to the check valve at port A, the pressure is held in the actuator even when the pump is turned off. Switching position: The flow blocked and the maximum pressure is allowed. The oil is drained via port T. The only oil leakage occurring is that the oil flows to port T during the switching process.</p>	<p>Symbol C</p> <p>3/2-way circuit with two poppet valves and cartridge check valve at port A The check valve is installed at port P of the 3/2-way directional poppet valve. Initial position: Descending Switch position: Lifting The load can be held in any position when the pump is turned off and the solenoid is energized.</p>
<p>Symbol C</p> <p>3/2-way circuit with two poppet valves Initial position: Descending Switch position: Lifting The maintenance of position only depends on the stroke limit and the pressure at port P.</p>	<p>Symbol U</p> <p>3/2-way circuit with a single poppet valve and cartridge check valve at port P The check valve is installed at port P of the 3/2-way poppet valve. Initial position: Lifting The load can be held in any position when the pump is turned off. Switching position: Descending</p>
<p>Symbol C</p>	<p>Symbol U</p> <p>4/3-way (4/4-way) circuit with two poppet valves and cartridge check valve at port P of the 3/2-way poppet valve V1 and V2 in the initial position: the piston is locked externally to prevent oil flow. V2 in the switching position: the piston moves to the right. V1 in the switching position: the piston moves to the left. V1 and V2 in the switching position: both ends of the cylinder are connected to the tank port. Attention! When using single rod cylinders, the performance limit (double flow) of the valve and the maximum allowable working pressure (overpressure) must be taken into account!</p>

Solenoid Operated Poppet Valve

Model: M-SEW10...1XJ



- ◆ Size 10
- ◆ Maximum working pressure 420/630 bar
- ◆ Maximum working flow 40 L/min

Contents

Function description, sectional drawing	02-03
Models and specifications	04
Technical parameters	05
Characteristic curve	06
Characteristic limit	06
Component size	07-09
Application examples	10

Features

- Direct operated solenoid directional poppet valve
- Closed port without leakage
- Switching flexibility even in high-pressure state long periods
- Air-gap DC solenoid with detachable coils (AC voltage available after rectification)
- The solenoid coil can be rotated by 90°
- Individual electrical connection