

Characteristic curve

(Measured when using HLP46, $\nu_{oil}=40^{\circ}\text{C} \pm 5^{\circ}\text{C}$)

Δp - q_v Characteristic curve

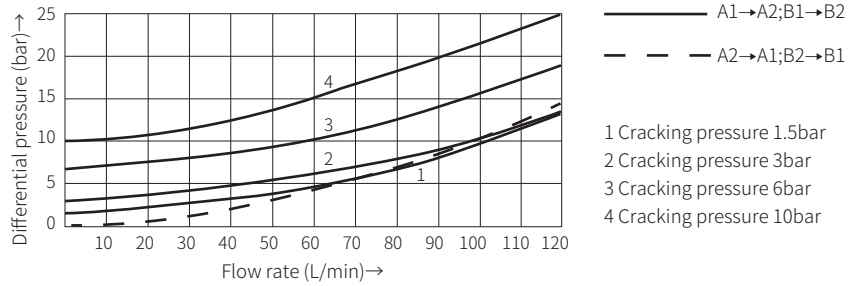

Component size

Size unit: mm

Model Z2S10...-3XJ/...

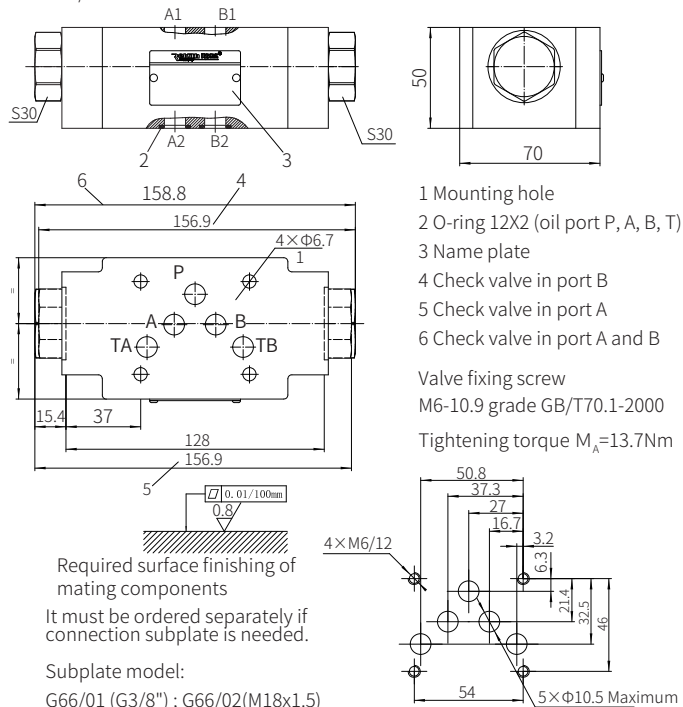

Modular Hydraulic Control Check Valve

Model: Z2S16...5XJ



- ◆ Size 16
- ◆ Maximum working pressure 315 bar
- ◆ Maximum working flow 300L/min

Contents

Function description, sectional drawing	02
Models and specifications	02
Functional symbols	03
Technical parameters	03
Characteristic curve	04
Component size	04

Features

- One or two working ports blocked without leakage
- For vertical installation
- 4 cracking pressures, optional

Function description, sectional drawing

The Z2S type is a superimposed structure hydraulically controlled check valve. This type of valve can keep one or two working oil ports leakage-free even if it is shut down for a long time.

There is a free flow in the direction A1 to A2 or B1 to B2 but closed in the opposite direction. When the oil flows from A1 to A2, the spool (1) is pushed to the right under pressure, opens the ball valve core (2) and then opens the sleeve valve core (3).

In order to ensure that the valve is closed correctly in the center position, the working oil port of the directional valve must be connected to the tank when it is in the neutral position (see circuit example).

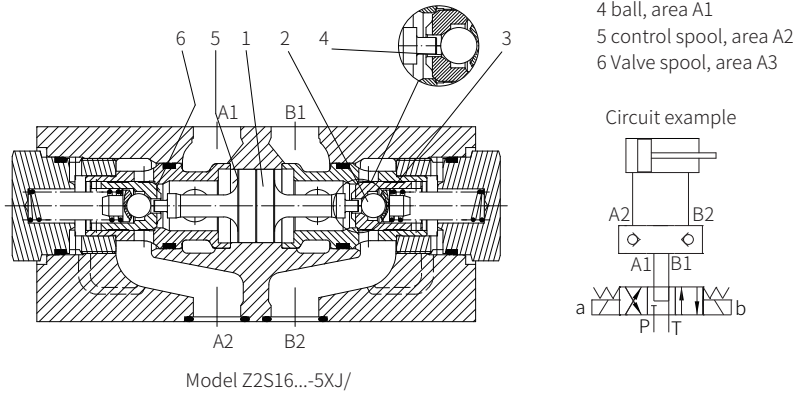

Models and specifications

Z2S	16		- 5X	J	*
modular hydraulic control check valve					more information in text
size 16	=16				
leakage-free blocking in oil ports A and B	=-				sealing material
oil port A	=A				No code= NBR seals
oil port B	=B				V= FKM seals (consult for other seals)
cracking pressure 3 bar	=1				J= Rekith
cracking pressure 5bar	=2				
cracking pressure 7.5bar	=3				5X= 50 to 59 series
cracking pressure 10bar	=4				(50 to 59 series installation and connection size unchanged)

Functional symbols

(①= Valve side, ②= Subplate side)

Model Z2S16A...

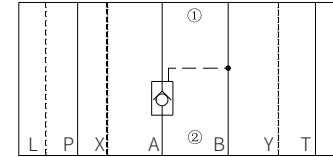

Model Z2S16...

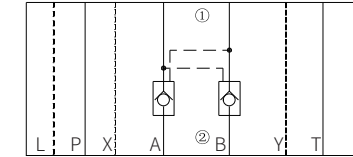

Model Z2S16B...

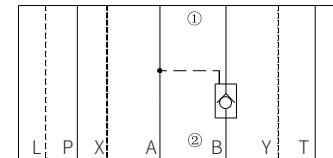

Technical parameters

Overview		
Installation position		Optional
Environmental temperature range	°C	-30 to +80 (NBR seal) -20 to +80 (FKM seal)
weight	kg	About 6.5
Hydraulic		
Maximum working pressure	bar	315
Maximum flow	L/min	300
Flow direction		See the symbol
Cracking pressure in free flow direction		See characteristic curve
Area ratio	L/min	A1/A2=1/11.8; A3/A2=1/2.8 (See section view above)
Pressure medium		Mineral oil (HL, HLP) ¹⁾ in accordance with DIN 51524; Fast living organisms degraded oil according to VDMA 24568; HETG (Rapeseed oil) ¹⁾ ; HEPG(Polyethyleneglycol) ²⁾ ; HEES (Synthetic Fats) ²⁾
Pressure medium temperature range	°C	-30 to +80 (NBR seal) -20 to +80 (FKM seal)
Viscosity range	mm ² /s	2.8 to 500
Cleanliness of oil		The maximum allowable pollution level of oil is ISO4406 level 20/18/15

1) For NBR seal and FKM seal.

2) Only for FKM seal.

3) The oil must meet the cleanliness degree requested by the components in the hydraulic system. Effective oil filtration can prevent failure and increase the service life of the components.

Characteristic curve

(Measured when using HLP46, $\vartheta_{oil}=40^{\circ}\text{C} \pm 5^{\circ}\text{C}$)

Δp - q_v Characteristic curve

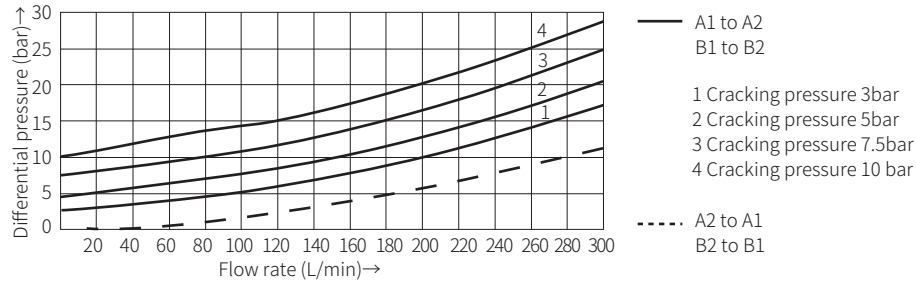

Component size

Size unit: mm

Model Z2S16...5XJ/...

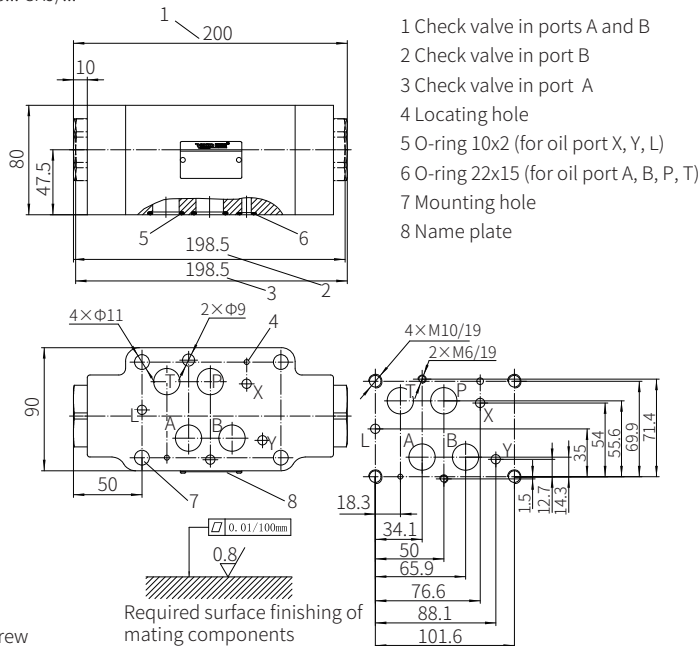

Valve fixing screw

M6-10.9 grade GB/T70.1-2000

Tightening torque $M_A=13.7\text{Nm}$

M10-10.9 grade GB/T70.1-2000

Tightening torque $M_A=60\text{Nm}$

Need to order separately

It must be ordered separately
if connection subplate is needed.

Subplate model:

G172/01 (G3/4"); G172/02 (M27x2)

G174/01 (G1"); G174/02 (M33x2)

Modular Hydraulic Control Check Valve

Model: Z2S22...5XJ



◆ Size 22

◆ Maximum working pressure 315 bar

◆ Maximum working flow 450 L/min

Contents

Function description, sectional drawing	02
Models and specifications	02
Functional symbols	03
Technical parameters	03
Characteristic curve	04
Component size	04

Features

- Modular valve
- One or two working oil ports blocked for leakage-free as required
- For vertical stacking installation
- 4 cracking pressures, optional