

## Modular Restrictive Check Valve

Model: Z2FS6...4XJ



- ◆ Size 6
- ◆ Maximum working pressure 315 bar
- ◆ Maximum working flow 80 L/min

### Contents

Function description, sectional drawing	02
Models and specifications	02
Functional symbols	03
Technical parameters	03
Characteristic curve	04
Component size	05

### Features

- Modular type valve
- 3 types of adjustment elements
  - Adjusting screw with inner hexagonal locknut and protective cap
  - Lockable knob with scale
  - Rotary knob with scale
- Used to limit the main flow or control flow of two working oil ports
- Used for meter-in or meter-out control

Any part of this brochure can not be reproduced, edited, copied and disseminated electronically in any way without authorization of Jiayite Hydraulics company. As the product is in constant development and innovation, the information in this brochure is not specific to the special conditions or applicability of a specific industry, thus Jiayite Hydraulics company is not responsible for any incomplete or inaccurate description generated.



## Function description, sectional drawing

The Z2FS6 type valve is a double throttle check valve with a stacked design.

This valve is used to limit the main flow or control flow of one or two working oil ports. Two symmetrically arranged throttle check valves limit the flow in one direction (by adjusting the throttle valve core) and allow free flow in the opposite direction.

For meter-in control the oil fluid flows from port A1 to A2 through the throttle port (1) which is made of the valve seat (2) and throttle spool (3). The throttle spool (3) can be axially adjusted via the adjusting screw (4) to adjust throttle port (1).

The fluid flowing back from the working oil port A2 opens the valve seat (2) against the force of spring (5) to make the valve to act as a check valve and allow free-flow. According to the installation position of the valve, the throttling effect can be meter-in or meter-out control.

Main flow limit (Z2FS6.../2Q)

To change velocity of the actuator (main flow control), the double throttle/check valve is installed between the directional control valve and the subplate.

Control flow limit (Z2FS6.../1Q)

In the pilot operated directional control valves, the double throttle/check valve is installed between the pilot valve and the main valve to control damping adjustment (control flow limit).

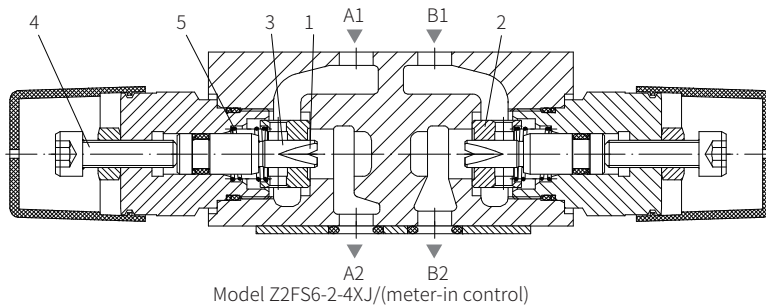

## Models and specifications

Z2FS	6	-4X	J	*
modular restrictive check Valve	=Z2FS			more information in text
size 6	=6			sealing material
throttle check valve, oil port A and B	=-			No code = NBR seals
throttle check valve, oil port A	=A			V= FKM seals
throttle check valve, oil port B	=B			(consult for other seals)
adjusting elements:				S= meter-in
adjusting screw with inner hexagonal locknut and protective cap	=2			S2= meter-out
lockable knob with scale	=3			1Q= with fine adjustment
rotary knob with scale	=7			2Q= standard type
40 to 49 series	=4X			J= Rekith
(40 to 49 series installation and connection size unchanged)				

## Functional symbols

(①=Valve side ②=Subplate side)

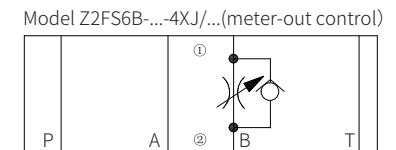
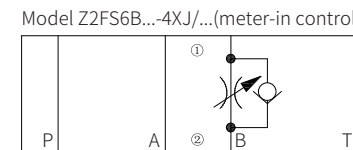
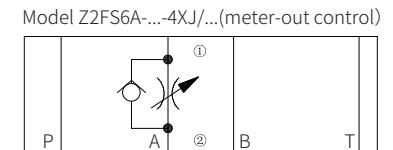
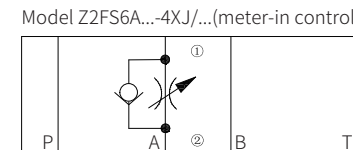
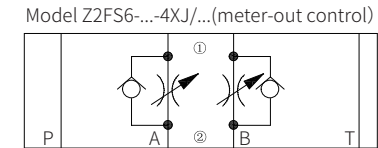
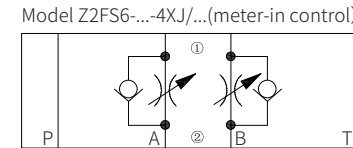

## Technical parameters

Overview	
Installation position	optional
Environment temperature range	°C -30 to +50 (NBR seal) -20 to +50 (FKM seal)
Weight	kg 0.8
Hydraulic	
Maximum working pressure	bar inlet port to 315
Maximum flow	L/min 80
Oil fluid	Mineral oil (HL, HLP) <sup>1)</sup> in accordance with DIN 51524; Fast living organisms Degraded oil according to VDMA 24568; HETG (Rapeseed oil) <sup>1)</sup> HEPG (Polyethylene glycol) <sup>2)</sup> HEES (synthetic ester) <sup>2)</sup>
Oil temperature range	°C -30 to +80 (NBR seal) -20 to +80 (FKM seal)
Viscosity range	mm <sup>2</sup> /s 10 to 800
Cleanliness of oil <sup>3)</sup>	The maximum allowable pollution level of oil is ISO4406 Class 20 / 18 / 15

1) For NBR seal and FKM seal.

2) Only for FKM seal.

3) The oil must meet the cleanliness degree requested by the components in the hydraulic system. Effective oil filtration can prevent failure and increase the service life of the components.

**Characteristic curve**

(Measured when using HLP 46,  $v_{oil} = 40^\circ\text{C} \pm 5^\circ\text{C}$ )

$\Delta p$ - $q_v$  characteristic curve Z2FS6...-4XJ/2QV  
Throttle setting in turns

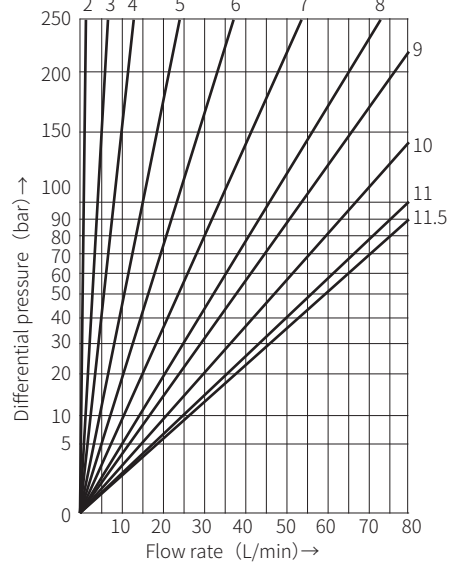

$\Delta p$ - $q_v$  characteristic curve Z2FS6...-4XJ/1QV  
Throttle setting in turns

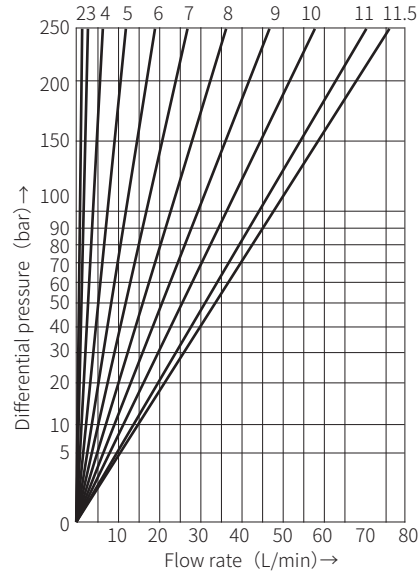

$\Delta p$ - $q_v$  characteristic curve via check valve (throttle valve closed)

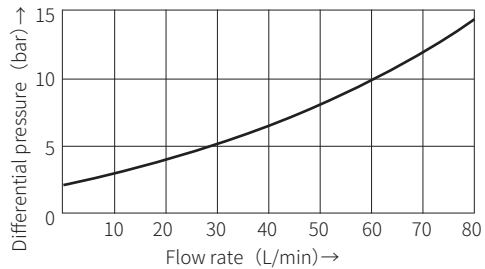

**Component size**

Size unit: mm

Model Z2FS6A-7-4XJ/...

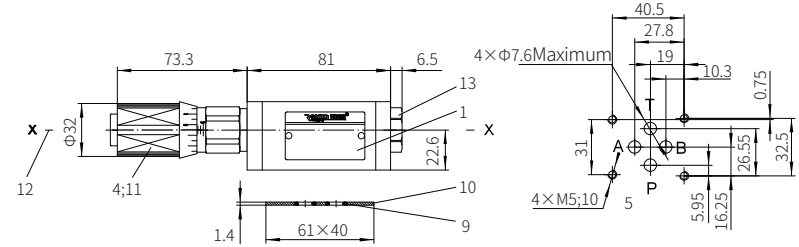

Model Z2FS6B-3-4XJ/...

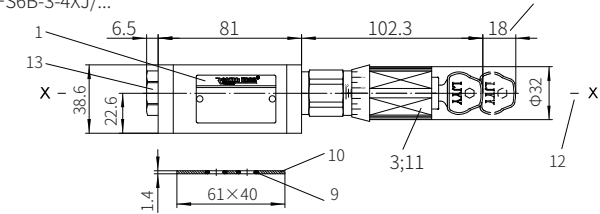

Model Z2FS6-2-4XJ/...

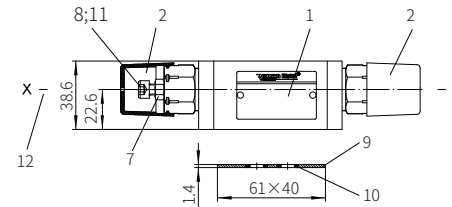

- 1 Name plate
- 2 Adjustment form "2"
- 3 Adjustment form "3"
- 4 Adjustment form "7"
- 5 Space required to remove key
- 6 Mounting hole of valve
- 7 Locking nut S=10
- 8 Inner hexagonal adjusting screw S=5
- 9 O-ring 9.25x1.78 (for oil port P, A, B, T)
- 10 O-ring plate
- 11 For all adjustment forms  
Turn anti-clockwise= increases flow  
Turn clockwise= decreases flow
- 12 Rotate the valve 180° around the "X-X" axis to change it from meter-in to meter-out
- 13 End cover S=22

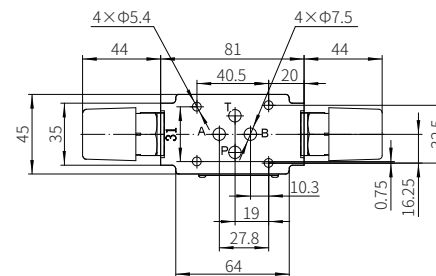

Valve fixing screw  
M5-10.9 grade GB/T70.1-2000  
Tightening torque  $M_A=7.8\text{Nm}$   
The length is determined by the stacking height and must be ordered separately.

