

Direct Operated Pressure Sequence Valve

Model: DZ10DP...4XJ



- ◆ Size 10
- ◆ Maximum working pressure 210 bar
- ◆ Maximum flow rate 80 L/min

Contents

Function description, sectional drawing	02
Models and specifications	02
Functional symbols	03
Technical parameters	03
Characteristic curve	04
Component size	05

Features

- 4 pressure ranges
- 2 adjusting elements
Rotary knob
Adjusting screw with protective cap
- Check valve , optional

Any part of this brochure can not be reproduced, edited, copied and disseminated electronically in any way without authorization of Jiayite Hydraulics company. As the product is in constant development and innovation, the information in this brochure is not specific to the special conditions or applicability of a specific industry, thus Jiayite Hydraulics company is not responsible for any incomplete or inaccurate description generated.



Function description, sectional drawing

The DZ10DP valve is direct operated sequence valve, it is used for sequence switching of the secondary circuit pressure. The sequence pressure is setting via the adjusting element (1).

The compression spring (2) holds the spool (3) in initial position, the valve is closed. The pressure in port A passes into the spool area via control line (4) to form a force which acts on the spool (3) opposite the compression spring (2). When the pressure reaches the setting value of the spring (2), the spool (3) is moved to connect port A and B. The systems connected with port B is sequenced while the pressure in port A will not drop. The control signal is obtained from port A via control line (4) or internally via port X. Based on the valve application, the leakage oil can return externally via port Y or internally via port B.

Notice!

For internal drainage, the set opening pressure increases the pressure in port B. The fluid oil can flow freely from port B to port A via installing check valve. Pressure gauge connection (6) is used to monitor the set sequential pressure.

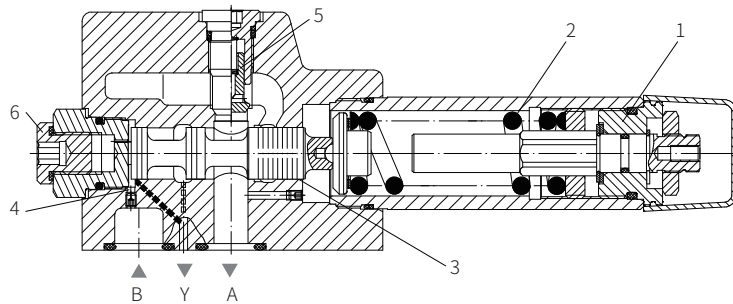

Model DZ10DP1-4XJ/...XY...

Models and specifications

DZ10DP - 4X J		*
direct operated sequence valve size 10		more information in text
adjusting element rotary knob = 1		sealing material
adjusting screw with protective cap = 2		No code= NBR seals
40 to 49 series = 4X		V= FKM seals (consult for other seals)
(40 to 49 series installation and connection size unchanged)		No code= with check valve
Rekith = J		M= without check valve
set pressure up to 25 bar = 25		No code= pilot oil supply and drain internal
set pressure up to 75 bar = 75		X= pilot oil supply external and drain internal
set pressure up to 150 bar = 150		Y= pilot oil supply internal and drain external
set pressure up to 210 bar = 210		XY= pilot oil supply and drain external

Functional symbols

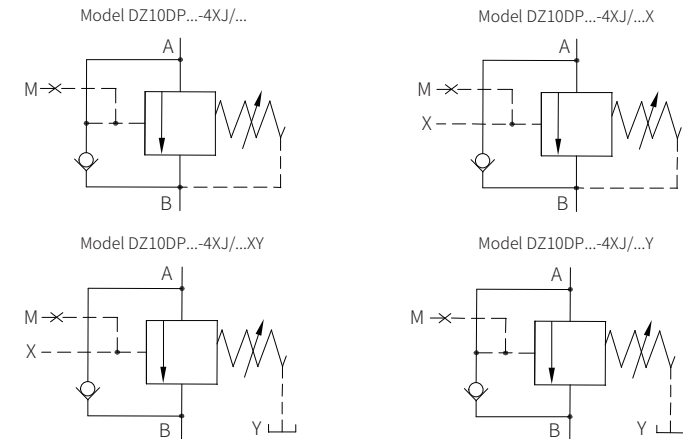

Technical parameters

Overview		
Installation position		optional
Environment temperature range	°C	-30 to +50 (NBR seal) -20 to +50 (FKM seal)
Weight	Kg	About 1.2

Hydraulic		
Maximum working pressure port P, A, B(X) bar		to 210
port T(Y) bar		to 160
Max. sequencing pressure (adjustable) bar		to 25; to 75; to 150; to 210
Max. flow L/min		to 80
Medium		Mineral oil (HL, HLP) ¹⁾ in accordance with DIN 51524; Fast living organisms degraded oil according to VDMA 24568; HETG (Rapeseed oil) ¹⁾ ; HEPG (Polyethyleneglycol) ²⁾ ; HEES (Synthetic Fats) ²⁾
Hydraulic oil temperature range	°C	-30 to +80 (NBR seal) -20 to +80 (FKM seal)
Viscosity range	mm ² /s	10 to 800
Cleanliness of oil ³⁾		The maximum allowable pollution level of oil is ISO4406 Class 20/18/15

1) For NBR seal and FKM seal.

2) Only for FKM seal.

3) The oil must meet the cleanliness degree requested by the components in the hydraulic system. Effective oil filtration can prevent failure and increase the service life of the components.

Characteristic curve

(Measured when using HLP46, $\vartheta_{oil}=40^{\circ}\text{C} \pm 5^{\circ}\text{C}$)

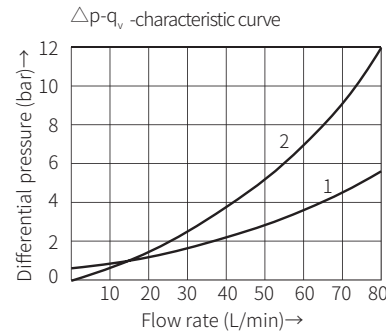
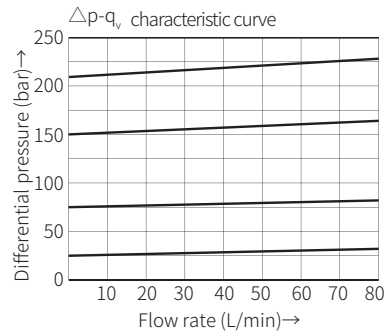

The characteristic curve is valid for an outlet pressure = 0 over the entire flow range!

$\Delta p-q_v$ -characteristic curve, B to A via check valve

$\Delta p-q_v$ -characteristic curve, A to B

Component size

Size unit: mm

Model DZ10DP...-4XJ/...

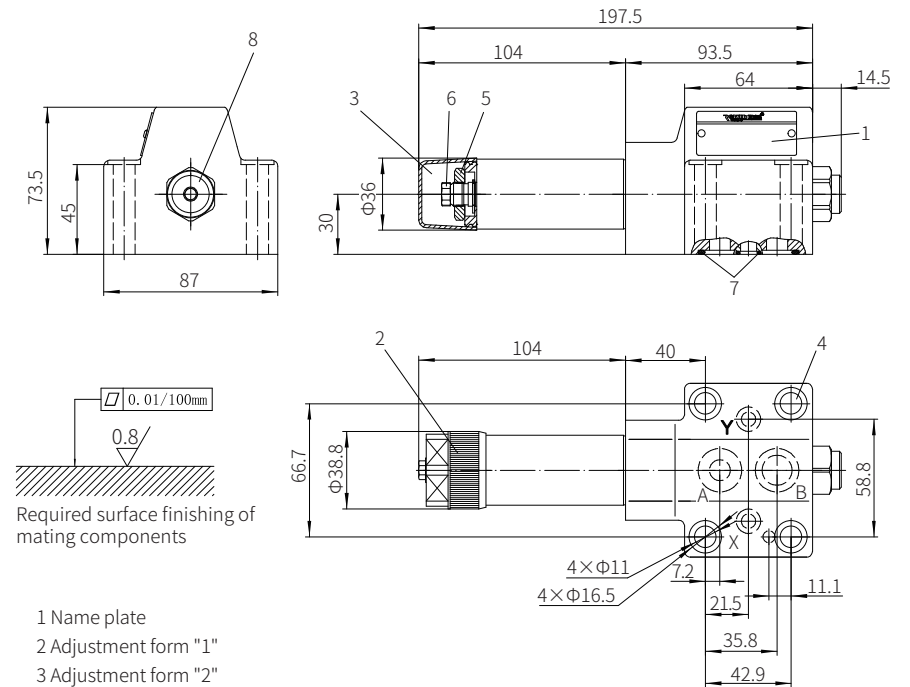

- 1 Name plate
- 2 Adjustment form "1"
- 3 Adjustment form "2"
- 4 Valve fixing screw hole
- 5 Locknut S=24
- 6 Internal hexagon adjusting screw S=10
- 7 O ring 8.75x1.8 (for oil port X, Y)
- 8 Pressure gauge connection:G1/4 or M14x1.5; 12 deep

Valve fixing screw
M10x60-10.9 grade GB/T70.1-2000
Tightening torque $M_A=60\text{Nm}$

It must be ordered separately
if connection subplate is needed.
Subplate model:
G460/01 (G3/8"); G460/02 (M18x1.5)
G461/01 (G1/2"); G461/02 (M22x1.5)