

Roller Directional Valve

Model: WMU/R6/10...



- ◆ Size 6/10
- ◆ Maximum working pressure 315 bar
- ◆ Maximum working flow 120 L/min

Contents

Functional description,sectional drawing	02
Models and specifications	02
Technical Parameters	03
Functional symbols	03
Characteristic curve	04
Characteristic limit	05
Component size	06-07

Features

- Right-angle directional valve operated by roller
- The roller can rotate 90°
- Interpolar conversion or deviation from the scanning direction by the curve control surface directly
- Radial direction (to 30° angle) is completely absorbed

Function description, sectional drawing

The WMR/U mechanical valve is direct operated directional spool valve with a roller/push rod controlled by a stopper or cam installed on the actuator.



There are 3/2-way, 4/2-way and 4/3-way valves with variety of symbols. The rollers and push rods can be rotated by 90°, and the radial direction (30°) is fully absorbed.

The valve consists of valve body (1), roller/push rod (2), control spool (3) and reset spring (4). When no external force operation, the control spool (3) is held in the initial position (switching position b) by the reset spring (4). When the external force operate the roller/push rod, the control spool (3) is pushed back to the initial position by the reset spring.

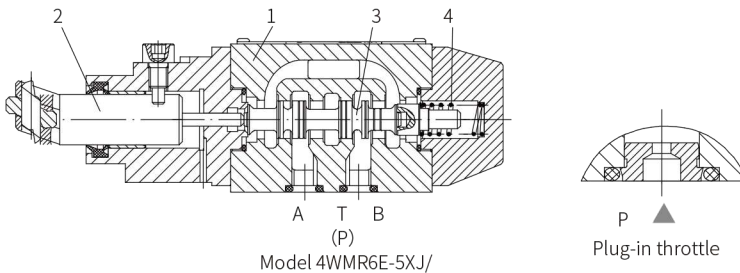
Due to limitations of working conditions, the flow of the valve may exceed the value of the performance curve during the switching process. In this case, a throttle is required to install in the P chamber of the valve or in the oil circuit.



Models and specifications

	WM				J		*
3 ways =3							more information in text
4 ways =4							sealing material
 = U							No code= NBR seals
 = R							V= FKM seals
							(consult for other seals)
size 6 =6							No code= without cartridge throttle
size 10 =10							B08= throttle Ø0.8mm
							B10= throttle Ø1.0mm
							B12= throttle Ø1.2mm
functional symbols					J=		Rekith
					5X=		50 to 59 series (for size 6)
							(50 to 59 series installation and connection size unchanged)
					3X=		30 to 39 series (for size 10)
							(30 to 39 series installation and connection size unchanged)

Technical parametes

Size	6		10	
Working pressure port A, B, P MPa	to 31.5			
port T MPa	to 6		to 16	
For symbols A and B, when the pressure exceeds the maximum return pressure, the oil port T must be used as a drain port				
Flow L/min	to 60		to 120	
Flow cross section (in the middle position)	For symbol Q, 6% of nominal cross-section			
	For symbol W, 3% of nominal cross-section			
Medium	Mineral hydraulic oil or phosphate ester hydraulic oil			
Oil temperature range °C	- 30 to + 80			
Viscosity range mm ² /s	2.8 to 500			
Weight kg	About 1.4		About 3.3	
Operating force on roller push rod N	Without return pressure	About 100 to 121	2-position valve	About 70 to 140
	With return pressure	About 184 to 205	3-position valve	About 70 to 175

01

Functional symbols

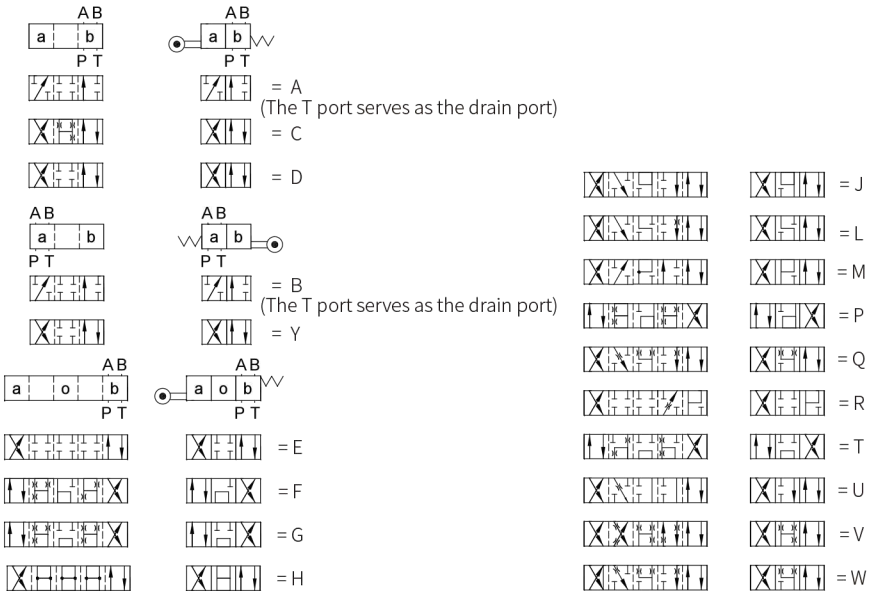

Characteristic curve

(Measured when using HLP46, $\vartheta_{oil} = 40^\circ\text{C} \pm 5^\circ\text{C}$)

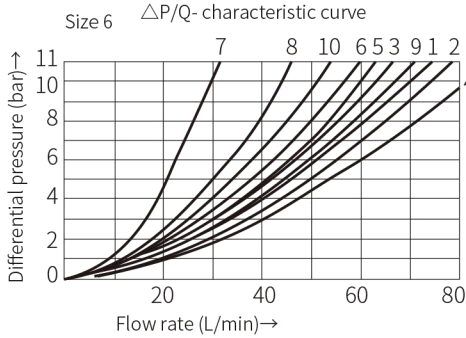

- 7 Symbol "R" in switching position B→A
- 8 Symbols "G" and "T" in the middle position P→T
- 9 Symbol "H" in the middle position P→T

Function symbol	Flow direction			
	P to A	P to B	A to T	B to T
AB	3	3	-	-
C	1	1	3	1
DY	5	5	3	3
E	3	3	1	1
F	1	3	1	1
T	10	10	9	9
H	2	4	2	2
JQ	1	1	2	1
L	3	3	4	9
M	2	4	3	3
P	3	1	1	1
R	5	5	4	-
V	1	2	1	1
W	1	1	2	2
U	3	3	9	4
G	6	6	9	9

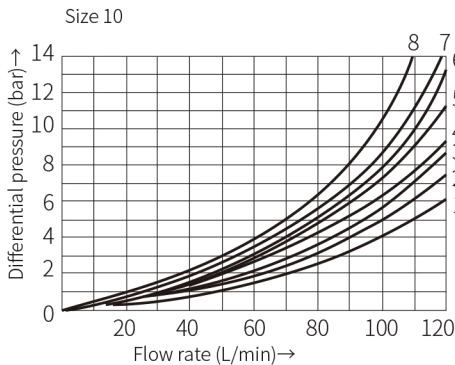

- 7 Symbol "R" in switching position B→A
- 8 Symbols "G" and "T" in the middle position P→T

Function symbol	Flow direction			
	P to A	P to B	A to T	B to T
A	4	3	-	-
B	3	4	-	-
C	3	3	4	4
D	3	3	5	5
E	2	2	4	4
F	1	2	3	4
G, T	4	4	7	7
H	1	1	5	5
J	2	2	3	3
L	3	3	2	4
M	1	1	4	4
P	3	1	5	5
Q	2	2	2	2
R	3	4	3	-
U	3	3	5	2
V	2	2	3	3
W	3	3	3	3
Y	4	4	6	6

Characteristic limit

(Measured when using HLP46, $\vartheta_{oil} = 40^\circ\text{C} \pm 5^\circ\text{C}$)

Due to blockage, the switching function of the valve is related to filtration. In order to obtain the maximum flow rate shown, 20u full flow filtration is recommended. Various forces acting on the valve also affect the flow characteristics. For four-way valves, the flow data shown are obtained under normal use of two flow directions (i.e., from P to A, while return from B to T) (see table).

If only one direction of flow is required, for example, block A or B of the four-way valve and use it as a three-way valve, its maximum flow rate will be greatly reduced in severe cases.

01

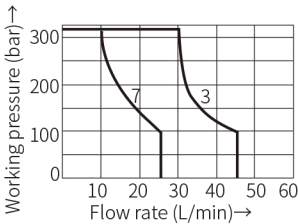
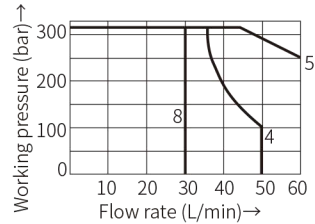
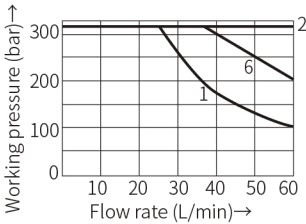

Characteristic curve	Function symbol
1	A, B
2	E, M, H, C, D, Y, Q, U, W
3	F, P
4	G
5	J, L
6	R
7	T
8	V

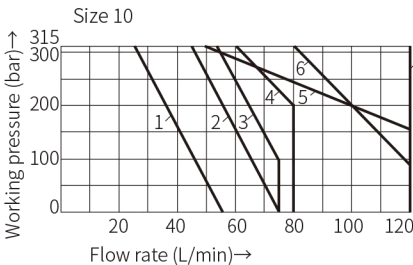

Characteristic curve	Function symbol
1	A, B
2	A/O
3	H
4	F, G, P, R, T
5	J, L, Q, U, W
6	C, D, E, M, V, Y
7	C/O, C/OF, D/O, D/OF

Component size

Size unit: mm

Model WMU/R10...

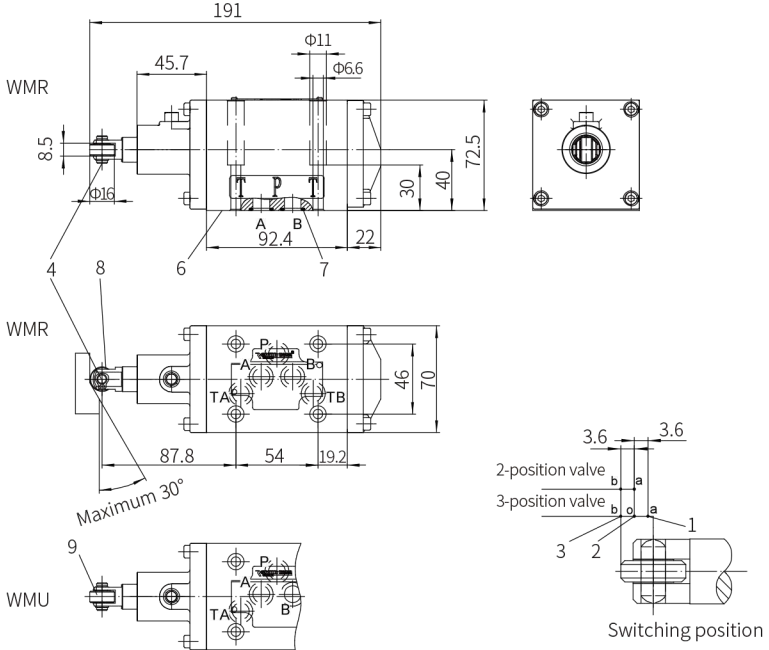

- 1 Switching position o→a
- 2 Switching position b→a, a→o, b→o
- 3 Switching position o→b, a→b
- 4 Pin
- 5 Name plate
- 6 Mounting surface
- 7 O-ring: 9.25x1.78 (for oil ports A, B, P, T)
- 8 Roller
- 9 Putter

It must be ordered separately if connection subplate is needed.

Subplate model:

- G66/01 (G3/8") ; G66/02 (M18x1.5)
- G67/01 (G1/2") ; G67/02 (M22x1.5)
- G534/01 (G3/4") ; G534/02 (M27x2)

Valve fixing screw

M6x40-10.9 grade GB/T70.1-2000

Tightening torque $M_A=13.7\text{Nm}$

